

**BY251 ... BY255, BY1600 ... BY2000**  
**Silicon Rectifier Diodes – Silizium-Gleichrichterdioden**

Version 2012-10-01

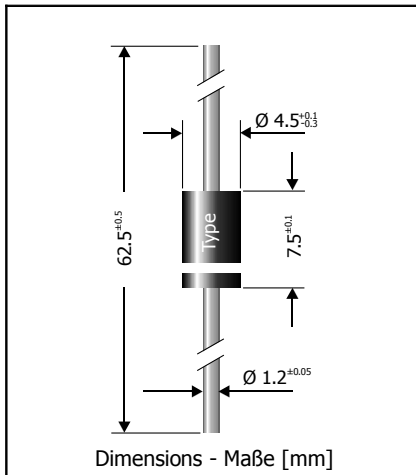

Nominal Current Nennstrom	3 A
Repetitive peak reverse voltage Periodische Spitzensperrspannung	200...2000 V
Plastic case Kunststoffgehäuse	~ DO-201
Weight approx. Gewicht ca.	0.8 g
Plastic material has UL classification 94V-0 Gehäusematerial UL94V-0 klassifiziert	
Standard packaging taped in ammo pack Standard Lieferform gegurtet in Ammo-Pack	



**Maximum ratings**

**Grenzwerte**

Type Typ	Repetitive peak reverse voltage Periodische Spitzensperrspannung $V_{RRM}$ [V]	Surge peak reverse voltage Stoßspitzensperrspannung $V_{RSM}$ [V]
BY251	200	200
BY252	400	400
BY253	600	600
BY254	800	800
BY255	1300	1300
BY1600	1600	1600
BY1800	1800	1800
BY2000	2000	2000
higher voltages see BY4...BY16	4000...16000	höhere Spannungen siehe 4000...16000

Max. average forward rectified current, R-load Dauergrenzstrom in Einwegschaltung mit R-Last	$T_A = 50^\circ\text{C}$	$I_{FAV}$	3 A <sup>1)</sup>
Repetitive peak forward current Periodischer Spitzenstrom	$f > 15$ Hz	$I_{FRM}$	20 A <sup>1)</sup>
Peak forward surge current, 50/60 Hz half sine-wave Stoßstrom für eine 50/60 Hz Sinus-Halbwelle	$T_A = 25^\circ\text{C}$	$I_{FSM}$	100/110 A
Rating for fusing, Grenzlasterintegral, $t < 10$ ms	$T_A = 25^\circ\text{C}$	$i^2t$	50 A <sup>2</sup> s
Junction temperature – Sperrschichttemperatur Storage temperature – Lagerungstemperatur		$T_j$ $T_s$	-50...+150°C -50...+175°C

1 Valid, if leads are kept at ambient temperature at a distance of 10 mm from case  
 Gültig, wenn die Anschlussdrähte in 10 mm Abstand von Gehäuse auf Umgebungstemperatur gehalten werden

**Characteristics**
**Kennwerte**

Forward voltage – Durchlass-Spannung	$T_j = 25^\circ\text{C}$ $I_F = 3\text{ A}$	$V_F$	< 1.1 V
Leakage current – Sperrstrom	$T_j = 25^\circ\text{C}$ $V_R = V_{RRM}$	$I_R$	< 5 $\mu\text{A}$
Thermal resistance junction to ambient air Wärmewiderstand Sperrschicht – umgebende Luft		$R_{thA}$	< 25 K/W <sup>1)</sup>
Thermal resistance junction to leads Wärmewiderstand Sperrschicht – Anschlussdraht		$R_{thL}$	< 10 K/W <sup>2)</sup>

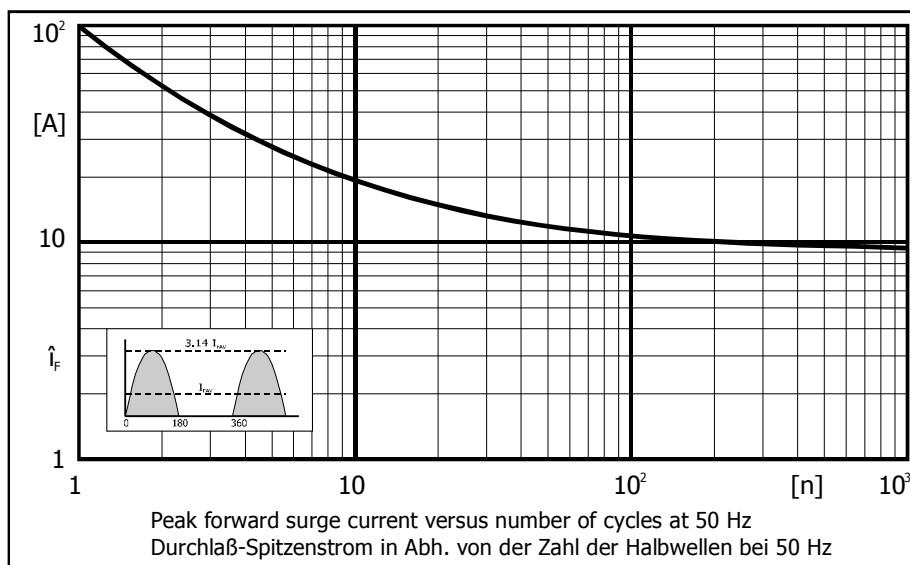
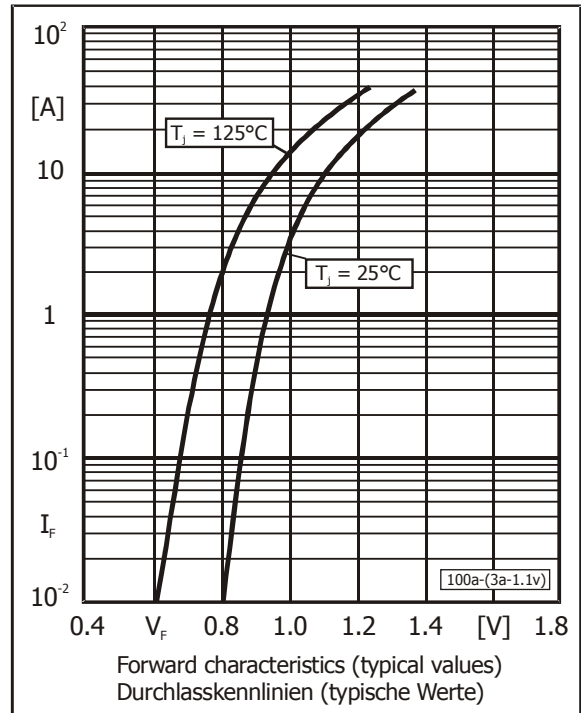
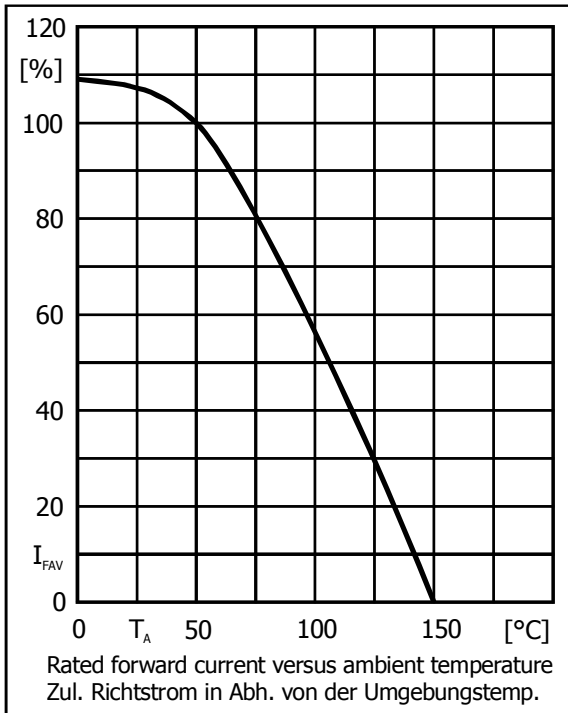

- Valid, if leads are kept at ambient temperature at a distance of 10 mm from case  
Gültig, wenn die Anschlussdrähte in 10 mm Abstand von Gehäuse auf Umgebungstemperatur gehalten werden
- Measured in 3 mm distance from case – use for bypass diodes test  
Gemessen in 3 mm Abstand vom Gehäuse – zu verwenden für Bypass-Diodentest