

RADIAL LEADED PTC AN MODEL

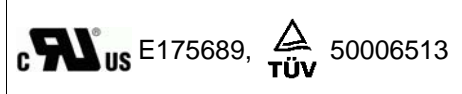

■ FEATURES

- Axial Leaded, low profile, solid state
- Full compatible with current industry standards
- Weldable nickel terminals
- Operation current: 1.2A~4.2 A
- Maximum voltage: 15V and 30V
- Temperature range -40°C to 85°C
- Cured, flame retardant epoxy polymer insulating material meets UL 94V-0 requirement
- Bulk packaging on most models

■ APPLICATIONS

- Rechargeable battery packs protection
- Lithium cell and battery packs
- Provides overcurrent protection with 125°C trip temperature

■ PART NUMBERING SYSTEM

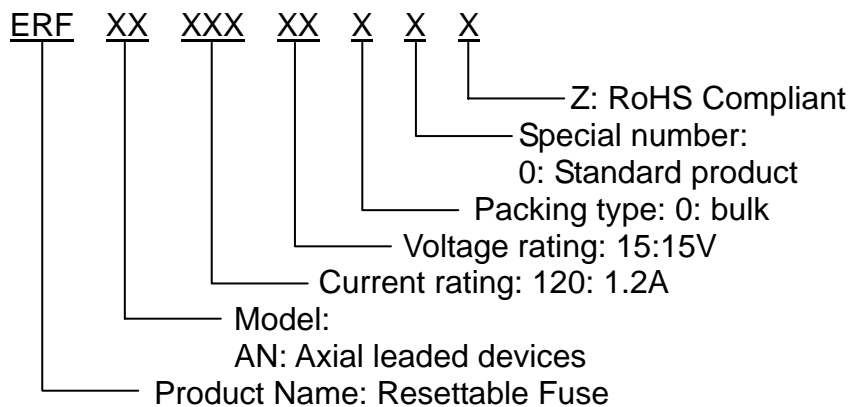

■ Marking system

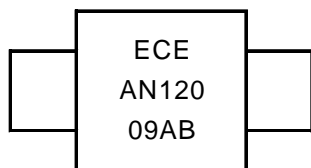

Example

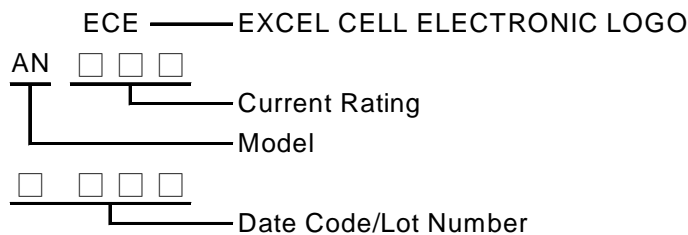

NOTE: Specifications subject to change without prior notice.

■ Electrical characteristics(23°C)

Part Number	Hold Current	Trip Current	Rated Voltage	Maximum Current	Typical Power	Resistance Tolerance		
	I _H , A	I _T , A	V _{MAX} , V _{dc}	I _{MAX} , A	P _d , W	R _{MIN}	R _{MAX}	R _{1MAX}
	Ω	Ω	Ω					
AN120	1.2	2.7	15	100	1.2	0.085	0.160	0.220
AN175	1.75	3.8	15	100	1.5	0.050	0.090	0.120
AN200	2.0	4.4	30	100	1.9	0.030	0.060	0.100
AN350	3.5	6.3	30	100	2.5	0.017	0.031	0.050
AN420	4.2	7.6	30	100	2.9	0.012	0.024	0.040

I_H=Hold current-maximum current at which the device will not trip at 23°C still air.

I_T=Trip current-minimum current at which the device will always trip at 23°C still air.

V_{MAX}=Maximum voltage device can withstand without damage at rated current.

I_{MAX}= Maximum fault current device can withstand without damage at rated voltage (V max).

P_d=Typical power dissipated from device when in the tripped state in 23°C still air environment.

R_{MIN}=Minimum device resistance at 23°C.

R_{1MAX}=Maximum device resistance at 23°C 1 hour after tripping .

■ Typical time-to-trip-at 23°C

A=AN120
B=AN175
C=AN200
D=AN350
E=AN420

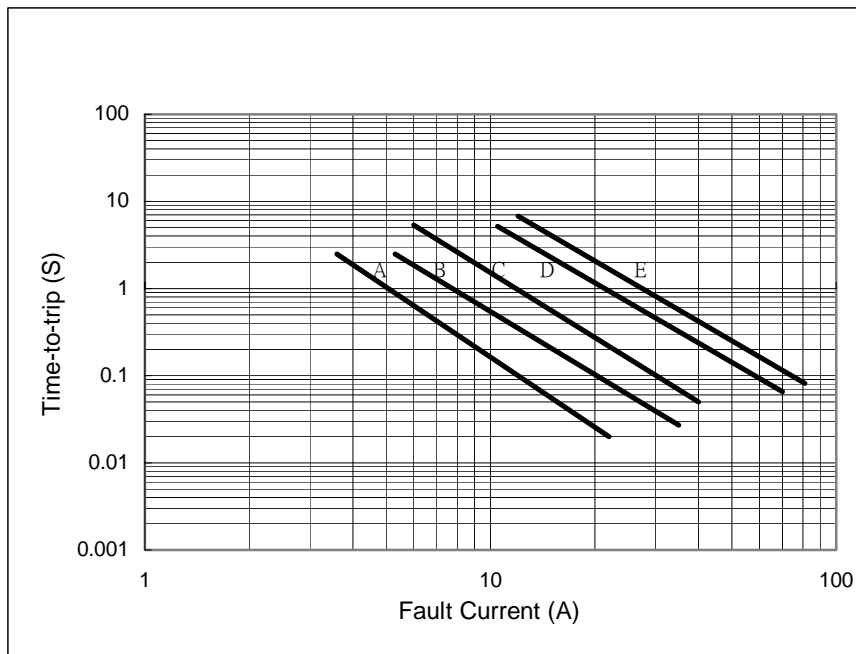

NOTE: Specifications subject to change without prior notice.

■ Thermal Derating Curve

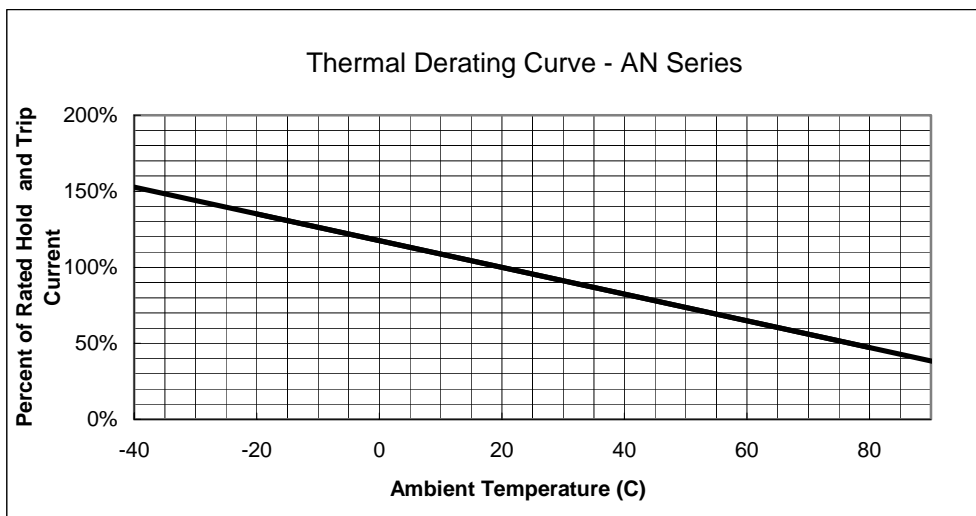

■ AN Product Dimensions (UNIT: mm)

Part Number	A		B		C		D		F	
	Min	Max	Min	Max	Min	Max	Min	Max	Min	Max
AN120	19.9	22.1	4.9	5.2	0.6	1.0	5.5	7.5	3.9	4.1
AN175	20.9	23.1	4.9	5.2	0.6	1.0	4.1	5.5	3.9	4.1
AN200	21.3	23.4	10.2	11.0	0.5	1.1	5.0	7.6	4.8	5.4
AN350	28.4	31.8	13.0	13.5	0.5	1.1	6.3	8.9	6.0	6.6
AN420	30.6	32.4	12.9	13.6	0.5	1.1	5.0	7.5	6.0	6.7

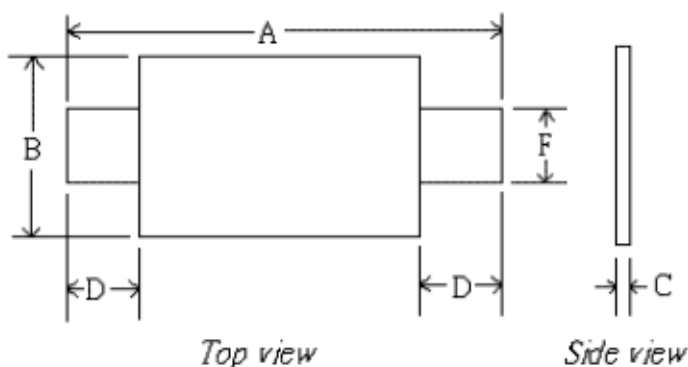

NOTE: Specifications subject to change without prior notice.