



Optimum power handling
Low on-state and switching losses
Designed for traction and industrial applications

Phase Control Stud Thyristor Type T271-250-8

Mean on-state current		I_{TAV}		250 A	
Repetitive peak off-state voltage		V_{DRM}		100÷800 V	
Repetitive peak reverse voltage		V_{RRM}			
Turn-off time		t_q		125 μ s	
V_{DRM}, V_{RRM}, V	100	200	400	600	800
Voltage code	1	2	4	6	8
$T_j, ^\circ C$	-60÷150				

MAXIMUM ALLOWABLE RATINGS

Symbols and parameters		Units	Values	Test conditions	
ON-STATE					
I_{TAV}	Mean on-state current	A	250 450	$T_c = 121 ^\circ C$; $T_c = 85 ^\circ C$; 180° half-sine wave; 50 Hz	
I_{TRMS}	RMS on-state current	A	393	$T_c = 121 ^\circ C$; 180° half-sine wave; 50 Hz	
I_{TSM}	Surge on-state current	kA	10.0 12.0	$T_j = T_{jmax}$ $T_j = 25 ^\circ C$	180° half-sine wave; 50 Hz ($t_p = 10$ ms); single pulse; $V_D = V_R = 0$ V; Gate pulse: $I_G = 2$ A; $t_{GP} = 50 \mu s$; $di_G/dt \geq 1$ A/ μs
			11.0 13.0	$T_j = T_{jmax}$ $T_j = 25 ^\circ C$	180° half-sine wave; 60 Hz ($t_p = 8.3$ ms); single pulse; $V_D = V_R = 0$ V; Gate pulse: $I_G = 2$ A; $t_{GP} = 50 \mu s$; $di_G/dt \geq 1$ A/ μs
I^2t	Safety factor	$A^2s \cdot 10^3$	500 720	$T_j = T_{jmax}$ $T_j = 25 ^\circ C$	180° half-sine wave; 50 Hz ($t_p = 10$ ms); single pulse; $V_D = V_R = 0$ V; Gate pulse: $I_G = 2$ A; $t_{GP} = 50 \mu s$; $di_G/dt \geq 1$ A/ μs
			500 700	$T_j = T_{jmax}$ $T_j = 25 ^\circ C$	180° half-sine wave; 60 Hz ($t_p = 8.3$ ms); single pulse; $V_D = V_R = 0$ V; Gate pulse: $I_G = 2$ A; $t_{GP} = 50 \mu s$; $di_G/dt \geq 1$ A/ μs
BLOCKING					
V_{DRM}, V_{RRM}	Repetitive peak off-state and Repetitive peak reverse voltages	V	100÷800	$T_{jmin} < T_j < T_{jmax}$; 180° half-sine wave; 50 Hz; Gate open	
V_{DSM}, V_{RSM}	Non-repetitive peak off-state and Non-repetitive peak reverse voltages	V	200÷900	$T_{jmin} < T_j < T_{jmax}$; 180° half-sine wave; 50 Hz; single pulse; Gate open	
V_D, V_R	Direct off-state and Direct reverse voltages	V	0.75· V_{DRM} 0.75· V_{RRM}	$T_j = T_{jmax}$; Gate open	

TRIGGERING				
I_{FGM}	Peak forward gate current	A	6	$T_j = T_{j\ max}$
V_{RGM}	Peak reverse gate voltage	V	5	
P_G	Gate power dissipation	W	3	$T_j = T_{j\ max}$ for DC gate current
SWITCHING				
$(di_T/dt)_{crit}$	Critical rate of rise of on-state current non-repetitive (f=1 Hz)	A/ μ s	320	$T_j = T_{j\ max}$; $V_D = 0.67 \cdot V_{DRM}$; $I_{TM} = 2 I_{TAV}$; Gate pulse: $I_G = 2$ A; $t_{GP} = 50$ μ s; $di_G/dt \geq 1$ A/ μ s
THERMAL				
T_{stg}	Storage temperature	$^{\circ}$ C	-60÷150	
T_j	Operating junction temperature	$^{\circ}$ C	-60÷150	
MECHANICAL				
M	Tightening torque	Nm	25÷35	
a	Acceleration	m/s ²	100	

CHARACTERISTICS

Symbols and parameters		Units	Values	Conditions
ON-STATE				
V_{TM}	Peak on-state voltage, max	V	1.50	$T_j = 25$ $^{\circ}$ C; $I_{TM} = 785$ A
$V_{T(TO)}$	On-state threshold voltage, max	V	0.95	$T_j = T_{j\ max}$; $0.5 \pi I_{TAV} < I_T < 1.5 \pi I_{TAV}$
r_T	On-state slope resistance, max	m Ω	0.760	
I_L	Latching current, max	mA	700	$T_j = 25$ $^{\circ}$ C; $V_D = 12$ V; Gate pulse: $I_G = 2$ A; $t_{GP} = 50$ μ s; $di_G/dt \geq 1$ A/ μ s
I_H	Holding current, max	mA	300	$T_j = 25$ $^{\circ}$ C; $V_D = 12$ V; Gate open
BLOCKING				
I_{DRM}, I_{RRM}	Repetitive peak off-state and Repetitive peak reverse currents, max	mA	70	$T_j = T_{j\ max}$; $V_D = V_{DRM}$; $V_R = V_{RRM}$
$(dv_D/dt)_{crit}$	Critical rate of rise of off-state voltage ¹⁾ , min	V/ μ s	1000	$T_j = T_{j\ max}$; $V_D = 0.67 \cdot V_{DRM}$; Gate open
TRIGGERING				
V_{GT}	Gate trigger direct voltage, max	V	4.00	$T_j = T_{j\ min}$ $T_j = 25$ $^{\circ}$ C $T_j = T_{j\ max}$ $V_D = 12$ V; $I_D = 3$ A; Direct gate current
			2.50	
			2.00	
I_{GT}	Gate trigger direct current, max	mA	400	$T_j = T_{j\ min}$ $T_j = 25$ $^{\circ}$ C $T_j = T_{j\ max}$
			250	
			200	
V_{GD}	Gate non-trigger direct voltage, min	V	0.25	$T_j = T_{j\ max}$; $V_D = 0.67 \cdot V_{DRM}$;
I_{GD}	Gate non-trigger direct current, min	mA	10.00	Direct gate current
SWITCHING				
t_{gd}	Delay time	μ s	1.60	$T_j = 25$ $^{\circ}$ C; $V_D = 0.4 \cdot V_{DRM}$; $I_{TM} = I_{TAV}$; Gate pulse: $I_G = 2$ A; $t_{GP} = 50$ μ s; $di_G/dt \geq 1$ A/ μ s
t_q	Turn-off time ²⁾ , max	μ s	125	$dv_D/dt = 50$ V/ μ s; $T_j = T_{j\ max}$; $I_{TM} = I_{TAV}$; $di_R/dt = -10$ A/ μ s; $V_R = 100$ V; $V_D = 0.67 \cdot V_{DRM}$;

THERMAL				
R_{thjc}	Thermal resistance, junction to case, max	°C/W	0.0800	Direct current
MECHANICAL				
w	Weight, typ	g	440	
D_s	Surface creepage distance	mm (inch)	12.4 (4.882)	
D_a	Air strike distance	mm (inch)	12.4 (4.882)	

PART NUMBERING GUIDE

T	271	250	8	N
1	2	3	4	5

1. Phase Control Thyristor
2. Design version
3. Mean on-state current, A
4. Voltage code
5. Ambient conditions: N – normal; T – tropical

OVERALL DIMENSIONS

Package type: T.SB1

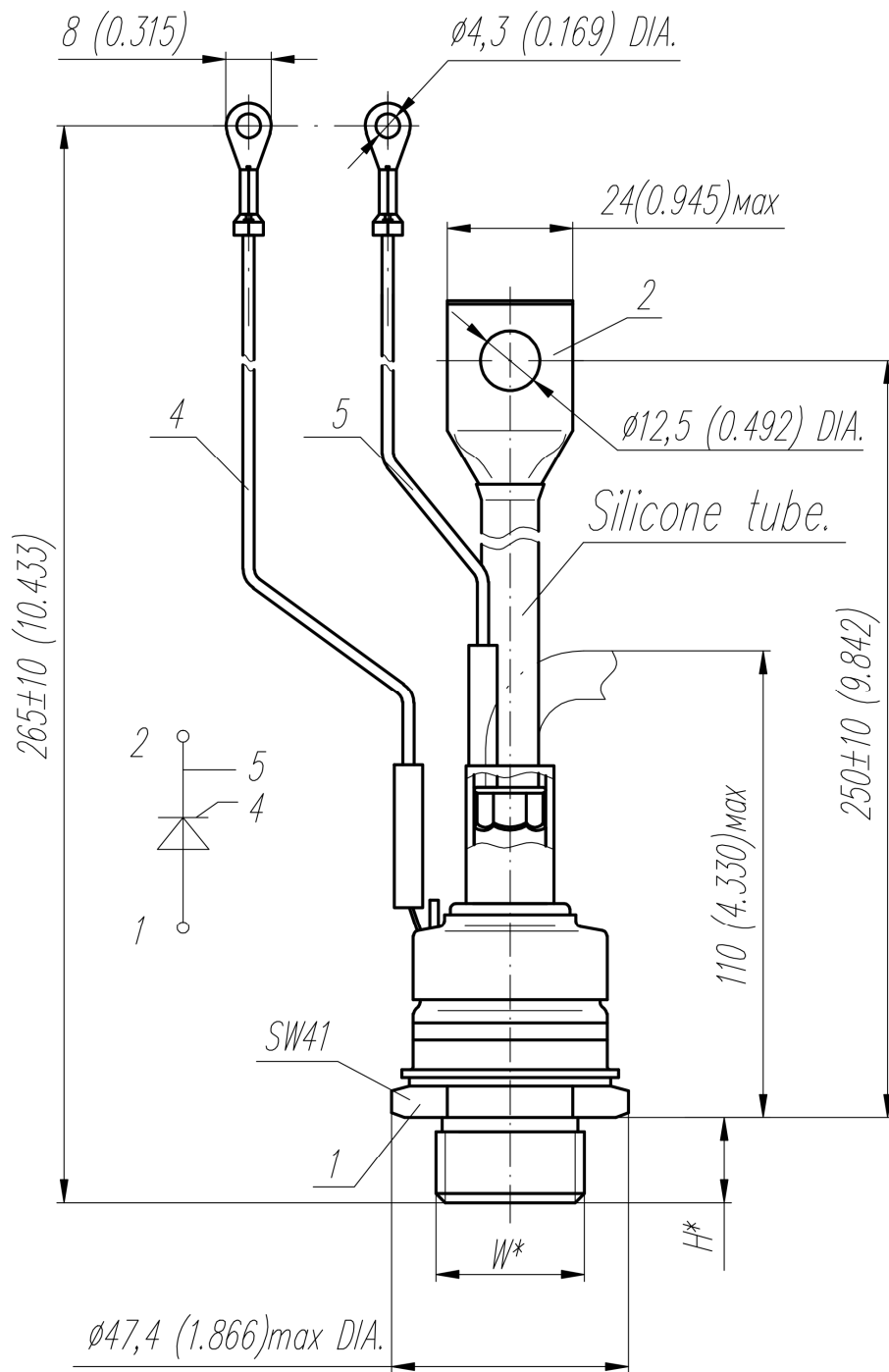

Type of screw	W	H
Metric Screw Type C	M24x1,5 – 8g	19
Metric Screw Type B (upon request)	M20x1,5 – 8g	15

Polarity	Example of code designation	Reference designation	Colors		
			Anode	Cathode	Gate
Anode to stud	T271-250-8		-	Red tube	White

All dimensions in millimeters (inches)

The information contained herein is confidential and protected by Copyright.

In the interest of product improvement, Proton-Electrotex reserves the right to change data sheet without notice.