

BOM LIST			
ITEM	PART NAME	Q'ty	NOTES
1	PLASTIC HOOD	2	SEE P/N
2	2.1 LONG BOLT	2	#4-40
	2.2 SHORT BOLT	2	#4-40
3	NUT	2	M3
4	LONG SCREW	2	M3
5	SMALL WASHER	2	
6	SHORT SCREW	2	M3
7	METAL WASHER	2	M3

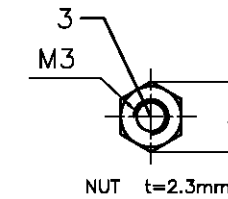
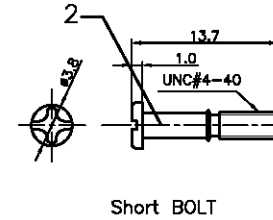
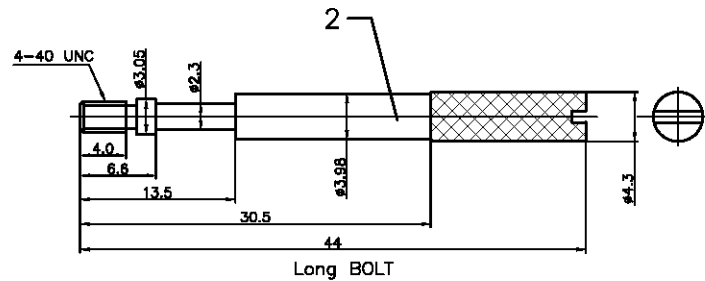
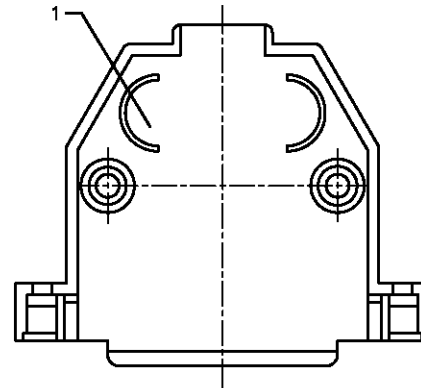

NOTES:
 1. Hardwares are all Nickel plated.
 2. PART NUMBER CODE:
 DS1045 - 25 X X X X X - X

Hood Materials (C)
 A: ABS
 B: Similar ABS

Washer type
 1: Metal

Bolt type
 L: Long
 S: Short

Packing type
 1: Mix packing
 2: Separation packing
 Q: Full packing

Cover Material
 P: Plastic(ABS)

Cover Color
 A: Gray
 B: Black
 V: Ivory

Position
 25: 25pin

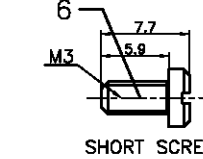
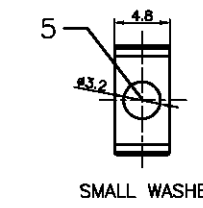
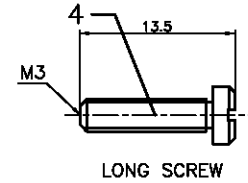

GENERAL TOLERANCE		ANGLE TOLERANCE	
X.	±0.60	X.	±5°
.X	±0.38	.X	±3°
.XX	±0.25	.XX	±2°

PROJECTION	TITLE	D-SUB Plastic Hood 180° 25 Positions	
UNITS	mm	SHEET SIZE	A4
SHEET SIZE	A4	SERIES	DS1045 SERIES

DRAWING TYPE	COSTOMER
SCALE	1:1 SHEET 1 OF 1
DRAWING NO.	C-DS1045-25XXXXX-X-G

 晨翔电子有限公司
CONNFY ELECTRONIC CO., LTD