



## Smart Highside Power Switch

### Features

- Overload protection
- Current limitation
- Short-circuit protection
- Thermal shutdown
- Overvoltage protection (including load dump)
- Fast demagnetization of inductive loads
- Reverse battery protection<sup>1)</sup>
- Undervoltage and overvoltage shutdown with auto-restart and hysteresis
- Open drain diagnostic output
- Open load detection in ON-state
- CMOS compatible input
- Loss of ground and loss of  $V_{bb}$  protection<sup>2)</sup>
- **Electrostatic discharge (ESD)** protection
- Green Product (RoHS compliant)
- AEC qualified

### Product Summary

Overvoltage protection	$V_{bb(AZ)}$	63 V
Operating voltage	$V_{bb(on)}$	4.5 ... 42 V
On-state resistance	$R_{ON}$	18 mΩ
Load current (ISO)	$I_L(ISO)$	21 A
Current limitation	$I_L(SCr)$	70 A

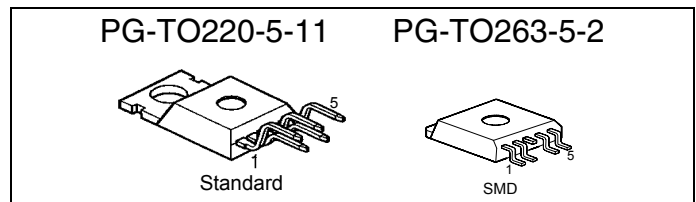

### Application

- $\mu C$  compatible power switch with diagnostic feedback for 12 V and 24 V DC grounded loads
- All types of resistive, inductive and capacitive loads
- Replaces electromechanical relays and discrete circuits

### General Description

N channel vertical power FET with charge pump, ground referenced CMOS compatible input and diagnostic feedback, integrated in Smart SIPMOS® chip on chip technology. Providing embedded protective functions.

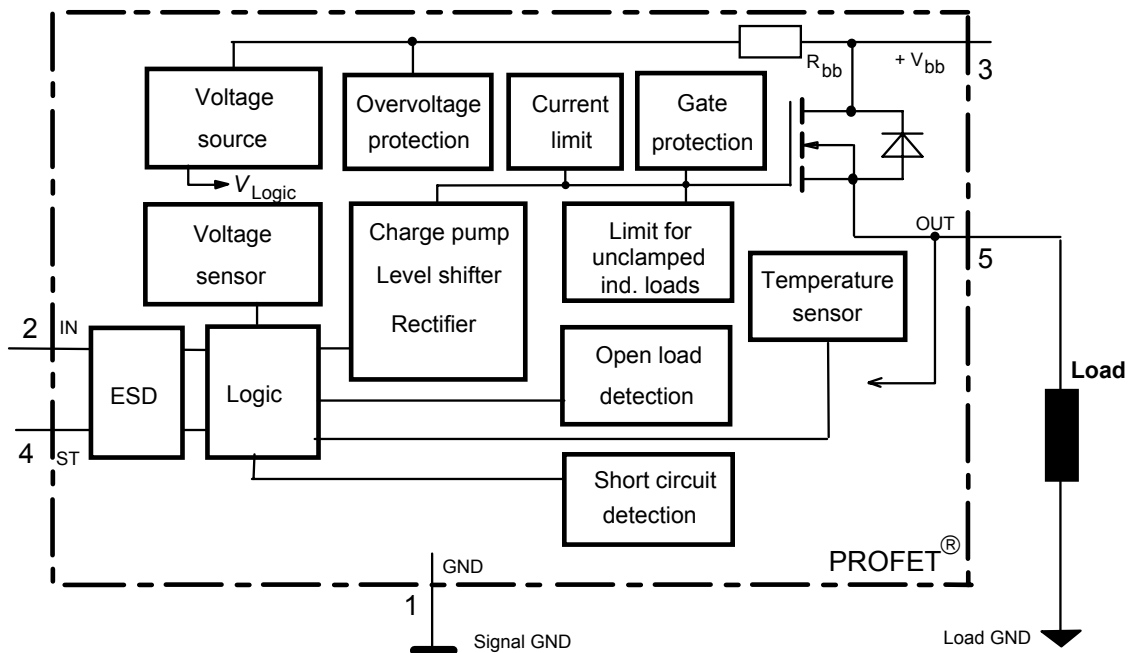

1) No external components required, reverse load current limited by connected load.  
 2) Additional external diode required for charged inductive loads

Pin	Symbol	Function
1	GND	Logic ground
2	IN	Input, activates the power switch in case of logical high signal
3	Vbb	Positive power supply voltage, the tab is shorted to this pin
4	ST	Diagnostic feedback, low on failure
5	OUT (Load, L)	Output to the load

**Maximum Ratings** at  $T_j = 25\text{ °C}$  unless otherwise specified

Parameter	Symbol	Values	Unit
Supply voltage (overvoltage protection see page 3)	$V_{bb}$	63	V
Load dump protection $V_{LoadDump} = U_A + V_s$ , $U_A = 13.5\text{ V}$ $R_i = 2\ \Omega$ , $R_L = 1.1\ \Omega$ , $t_d = 200\text{ ms}$ , IN= low or high	$V_{Load\ dump}^{3)}$	80	V
Load current (Short-circuit current, see page 4)	$I_L$	self-limited	A
Operating temperature range	$T_j$	-40 ... +150	°C
Storage temperature range	$T_{stg}$	-55 ... +150	
Power dissipation (DC)	$P_{tot}$	167	W
Inductive load switch-off energy dissipation, single pulse $T_j = 150\text{ °C}$ :	$E_{AS}$	2.1	J
Electrostatic discharge capability (ESD) (Human Body Model)	$V_{ESD}$	2.0	kV
Input voltage (DC)	$V_{IN}$	-0.5 ... +6	V
Current through input pin (DC)	$I_{IN}$	$\pm 5.0$	mA
Current through status pin (DC) see internal circuit diagrams page 6...	$I_{ST}$	$\pm 5.0$	
Thermal resistance	chip - case: $R_{thJC}$ junction - ambient (free air): $R_{thJA}$ SMD version, device on pcb <sup>4)</sup> :	$\leq 0.75$ $\leq 75$ typ. 33	K/W

3)  $V_{Load\ dump}$  is setup without the DUT connected to the generator per ISO 7637-1 and DIN 40839

4) Device on 50mm\*50mm\*1.5mm epoxy PCB FR4 with 6cm<sup>2</sup> (one layer, 70µm thick) copper area for  $V_{bb}$  connection. PCB is vertical without blown air.

## Electrical Characteristics

Parameter and Conditions at $T_j = 25\text{ °C}$ , $V_{bb} = 12\text{ V}$ unless otherwise specified	Symbol	Values			Unit
		min	typ	max	

### Load Switching Capabilities and Characteristics

On-state resistance (pin 3 to 5) $I_L = 5\text{ A}$	$T_j = 25\text{ °C}$ : $T_j = 150\text{ °C}$ :	$R_{ON}$	--	15 28	18 35	mΩ
Nominal load current (pin 3 to 5) ISO Proposal: $V_{ON} = 0.5\text{ V}$ , $T_C = 85\text{ °C}$		$I_{L(ISO)}$	17	21	--	A
Output current (pin 5) while GND disconnected or GND pulled up, $V_{IN} = 0$ , see diagram page 7, $T_j = -40\dots+150\text{ °C}$		$I_{L(GNDhigh)}$	--	--	1	mA
Turn-on time to 90% $V_{OUT}$ :		$t_{on}$	100	--	350	μs
Turn-off time to 10% $V_{OUT}$ :		$t_{off}$	10	--	130	
Slew rate on 10 to 30% $V_{OUT}$ , $R_L = 12\text{ Ω}$ , $T_j = -40\dots+150\text{ °C}$		$dV/dt_{on}$	0.2	--	2	V/μs
Slew rate off 70 to 40% $V_{OUT}$ , $R_L = 12\text{ Ω}$ , $T_j = -40\dots+150\text{ °C}$		$-dV/dt_{off}$	0.4	--	5	V/μs

### Operating Parameters

Operating voltage <sup>5)</sup>	$T_j = -40\dots+150\text{ °C}$ :	$V_{bb(on)}$	4.5	--	42	V
Undervoltage shutdown	$T_j = -40\dots+150\text{ °C}$ :	$V_{bb(under)}$	2.4	--	4.5	V
Undervoltage restart	$T_j = -40\dots+150\text{ °C}$ :	$V_{bb(u\text{ rst})}$	--	--	4.5	V
Undervoltage restart of charge pump see diagram page 12	$T_j = -40\dots+150\text{ °C}$ :	$V_{bb(ucp)}$	--	6.5	7.5	V
Undervoltage hysteresis $\Delta V_{bb(under)} = V_{bb(u\text{ rst})} - V_{bb(under)}$		$\Delta V_{bb(under)}$	--	0.2	--	V
Overvoltage shutdown	$T_j = -40\dots+150\text{ °C}$ :	$V_{bb(over)}$	42	--	52	V
Overvoltage restart	$T_j = -40\dots+150\text{ °C}$ :	$V_{bb(o\text{ rst})}$	42	--	--	V
Overvoltage hysteresis	$T_j = -40\dots+150\text{ °C}$ :	$\Delta V_{bb(over)}$	--	0.2	--	V
Overvoltage protection <sup>6)</sup> $I_{bb} = 40\text{ mA}$	$T_j = -40\text{ °C}$ : $T_j = 25\dots+150\text{ °C}$ :	$V_{bb(AZ)}$	60 63	--	--	V
Standby current (pin 3) $V_{IN} = 0$	$T_j = -40\dots+25\text{ °C}$ : $T_j = 150\text{ °C}$ :	$I_{bb(off)}$	--	12 18	25 60	μA
Leakage output current (included in $I_{bb(off)}$ ) $V_{IN} = 0$		$I_{L(off)}$	--	6	--	μA
Operating current (Pin 1) <sup>7)</sup> , $V_{IN} = 5\text{ V}$		$I_{GND}$	--	1.1	--	mA

5) At supply voltage increase up to  $V_{bb} = 6.5\text{ V}$  typ without charge pump,  $V_{OUT} \approx V_{bb} - 2\text{ V}$

6) see also  $V_{ON(CL)}$  in table of protection functions and circuit diagram page 7. Measured without load.

7) Add  $I_{ST}$ , if  $I_{ST} > 0$ , add  $I_{IN}$ , if  $V_{IN} > 5.5\text{ V}$

Parameter and Conditions at $T_j = 25\text{ °C}$ , $V_{bb} = 12\text{ V}$ unless otherwise specified	Symbol	Values			Unit
		min	typ	max	
<b>Protection Functions<sup>8)</sup></b>					
Initial peak short circuit current limit (pin 3 to 5) <sup>9)</sup> , (max 400 $\mu\text{s}$ if $V_{ON} > V_{ON(SC)}$ )	$I_{L(SCp)}$				
$T_j = -40\text{ °C}$ :		--	--	140	A
$T_j = 25\text{ °C}$ :		--	95	--	
$T_j = +150\text{ °C}$ :		45	--	--	
Repetitive short circuit current limit $T_j = T_{jt}$ (see timing diagrams, page 10)	$I_{L(SCr)}$	30	70	--	A
Short circuit shutdown delay after input pos. slope $V_{ON} > V_{ON(SC)}$ , min value valid only, if input "low" time exceeds 30 $\mu\text{s}$	$t_{d(SC)}$	80	--	400	$\mu\text{s}$
Output clamp (inductive load switch off) at $V_{OUT} = V_{bb} - V_{ON(CL)}$ , $I_L = 30\text{ mA}$	$V_{ON(CL)}$	--	58	--	V
Short circuit shutdown detection voltage (pin 3 to 5)	$V_{ON(SC)}$	--	8.3	--	V
Thermal overload trip temperature	$T_{jt}$	150	--	--	$\text{°C}$
Thermal hysteresis	$\Delta T_{jt}$	--	10	--	K
Inductive load switch-off energy dissipation <sup>10)</sup> , $T_{j\text{ Start}} = 150\text{ °C}$ , single pulse	$E_{AS}$	--	--	2.1	J
$V_{bb} = 12\text{ V}$ :	$E_{Load12}$			1.7	
$V_{bb} = 24\text{ V}$ :	$E_{Load24}$			1.2	
Reverse battery (pin 3 to 1) <sup>11)</sup>	$-V_{bb}$	--	--	32	V
Integrated resistor in $V_{bb}$ line	$R_{bb}$	--	120	--	$\Omega$

### Diagnostic Characteristics



Open load detection current (on-condition)	$T_j = -40\text{ °C}$ : $T_j = 25\text{..}150\text{ °C}$ :	$I_L(OL)$	2 2	-- --	1900 1500	mA
---	---	-----------	--------	----------	--------------	----

8) Integrated protection functions are designed to prevent IC destruction under fault conditions described in the data sheet. Fault conditions are considered as "outside" normal operating range. Protection functions are not designed for continuous repetitive operation.

9) Short circuit current limit for max. duration of  $t_{d(SC)} \text{ max} = 400\text{ }\mu\text{s}$ , prior to shutdown

10) While demagnetizing load inductance, dissipated energy in PROFET is  $E_{AS} = \int V_{ON(CL)} * I_L(t) dt$ , approx.  
 $E_{AS} = \frac{1}{2} * L * I_L^2 * (\frac{V_{ON(CL)}}{V_{ON(CL)} - V_{bb}})$ , see diagram page 8.

11) Reverse load current (through intrinsic drain-source diode) is normally limited by the connected load. Reverse current  $I_{GND}$  of  $\approx 0.3\text{ A}$  at  $V_{bb} = -32\text{ V}$  through the logic heats up the device. Time allowed under these condition is dependent on the size of the heatsink. Reverse  $I_{GND}$  can be reduced by an additional external GND-resistor (150  $\Omega$ ). Input and Status currents have to be limited (see max. ratings page 2 and circuit page 7).

Parameter and Conditions at $T_j = 25\text{ °C}$ , $V_{bb} = 12\text{ V}$ unless otherwise specified	Symbol	Values			Unit
		min	typ	max	
<b>Input and Status Feedback<sup>12)</sup></b>					
Input turn-on threshold voltage  $T_j = -40\dots+150\text{ °C}$ :	$V_{IN(T+)}$	1.5	--	2.4	V
Input turn-off threshold voltage  $T_j = -40\dots+150\text{ °C}$ :	$V_{IN(T-)}$	1.0	--	--	V
Input threshold hysteresis	$\Delta V_{IN(T)}$	--	0.5	--	V
Off state input current (pin 2), $V_{IN} = 0.4\text{ V}$	$I_{IN(off)}$	1	--	30	$\mu\text{A}$
On state input current (pin 2), $V_{IN} = 3.5\text{ V}$	$I_{IN(on)}$	10	25	50	$\mu\text{A}$
Status invalid after positive input slope (short circuit) $T_j = -40\dots+150\text{ °C}$ :	$t_{d(ST\ SC)}$	80	200	400	$\mu\text{s}$
Status invalid after positive input slope (open load) $T_j = -40\dots+150\text{ °C}$ :	$t_{d(ST)}$	350	--	1600	$\mu\text{s}$
Status output (open drain) Zener limit voltage $T_j = -40\dots+150\text{ °C}$ , $I_{ST} = +1.6\text{ mA}$ :	$V_{ST(high)}$	5.4	6.1	--	V
ST low voltage $T_j = -40\dots+150\text{ °C}$ , $I_{ST} = +1.6\text{ mA}$ :	$V_{ST(low)}$	--	--	0.4	

<sup>12)</sup> If a ground resistor  $R_{GND}$  is used, add the voltage drop across this resistor.

### Truth Table

	Input-level	Output level	Status
			442 E2
Normal operation	L	L	H
	H	H	H
Open load	L	13)	H
	H	H	L
Short circuit to GND	L	L	H
	H	L	L
Short circuit to V <sub>bb</sub>	L	H	H
	H	H	H (L <sup>14</sup> )
Overtemperature	L	L	L
	H	L	L
Undervoltage	L	L	H
	H	L	H
Overvoltage	L	L	H
	H	L	H

L = "Low" Level  
H = "High" Level

### Terms

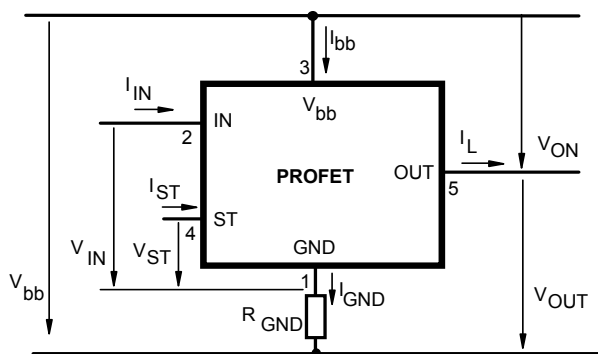

### Input circuit (ESD protection)

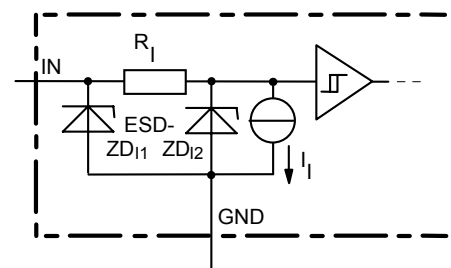

ZD11 6.1 V typ., ESD zener diodes are not to be used as voltage clamp at DC conditions. Operation in this mode may result in a drift of the zener voltage (increase of up to 1 V).

13) Power Transistor off, high impedance

14) Low resistance short V<sub>bb</sub> to output may be detected by no-load-detection

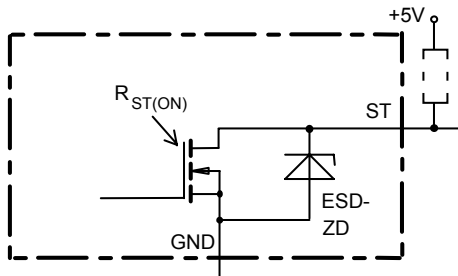
**Status output**

ESD-Zener diode: 6.1 V typ., max 5 mA;  
 $R_{ST(ON)} < 250 \Omega$  at 1.6 mA, ESD zener diodes are not to be used as voltage clamp at DC conditions.  
 Operation in this mode may result in a drift of the zener voltage (increase of up to 1 V).

**Short Circuit detection**

Fault Condition:  $V_{ON} > 8.3 \text{ V typ.}$ ; IN high

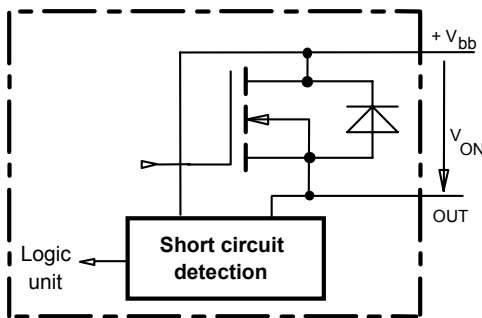
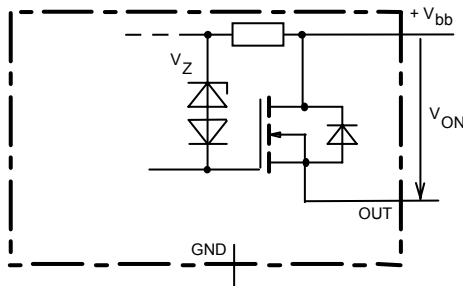
**Inductive and overvoltage output clamp**

$V_{ON}$  clamped to 58 V typ.

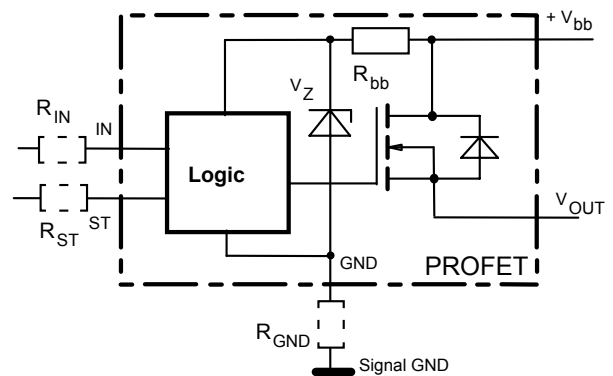
**Overvolt. and reverse batt. protection**

$R_{bb} = 120 \Omega$  typ.,  $V_Z + R_{bb} * 40 \text{ mA} = 67 \text{ V typ.}$ , add  $R_{GND}$ ,  $R_{IN}$ ,  $R_{ST}$  for extended protection

**Open-load detection**

ON-state diagnostic condition:  $V_{ON} < R_{ON} * I_{L(OL)}$ ; IN high

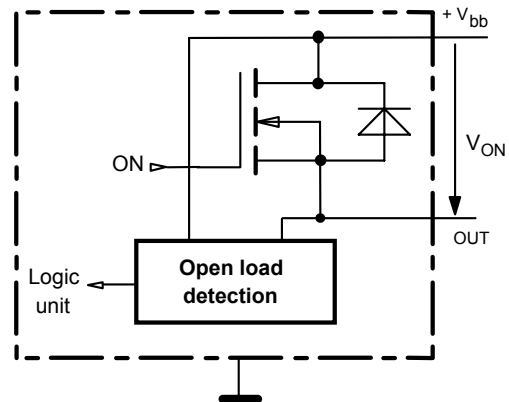
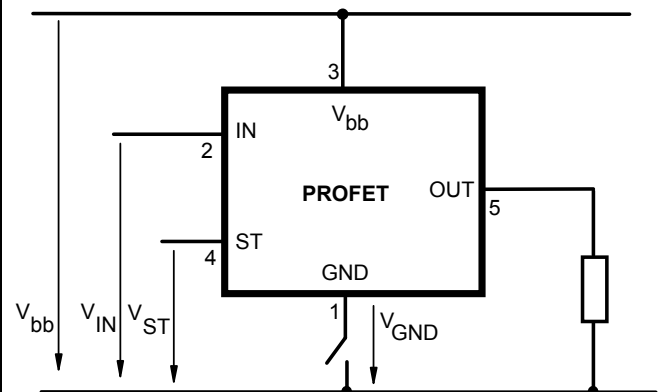
**GND disconnect**

Any kind of load. In case of Input=high is  $V_{OUT} \approx V_{IN} - V_{IN(T+)}$ .  
 Due to  $V_{GND} > 0$ , no  $V_{ST} = \text{low}$  signal available.

**GND disconnect with GND pull up**

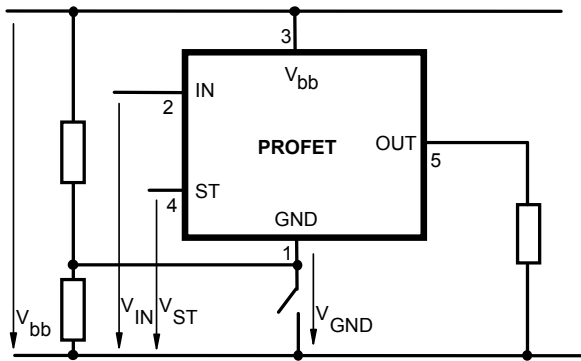

Any kind of load. If  $V_{GND} > V_{IN} - V_{IN(T+)}$  device stays off  
 Due to  $V_{GND} > 0$ , no  $V_{ST} = \text{low signal}$  available.

**Vbb disconnect with charged inductive load**

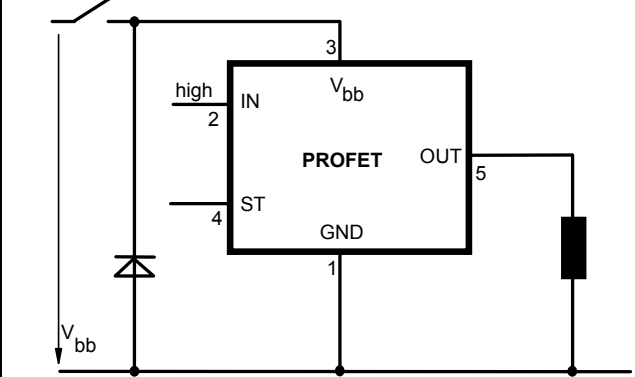
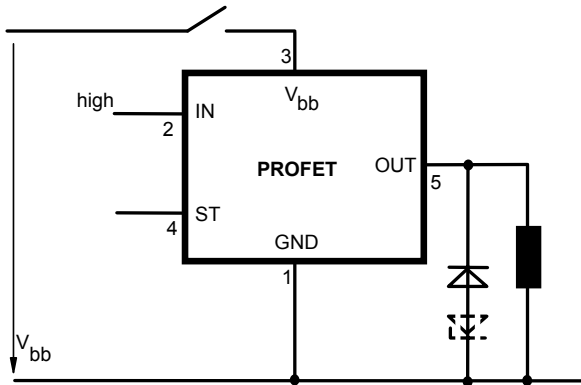

**Inductive Load switch-off energy dissipation**

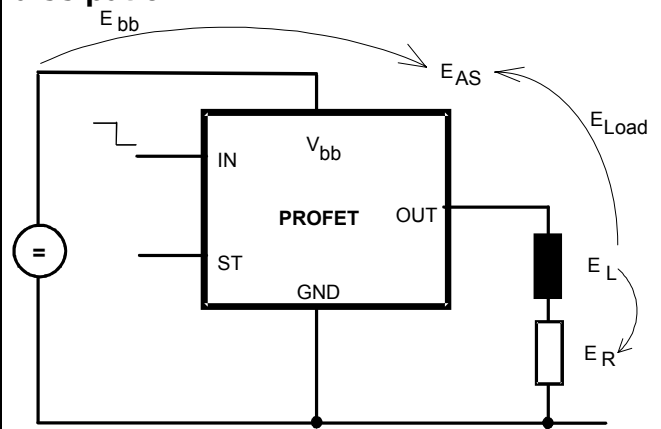

Energy dissipated in PROFET  $E_{AS} = E_{bb} + E_L - E_R$ .  
 $E_{Load} < E_L$ ,  $E_L = 1/2 * L * I_L^2$



## Options Overview

**all versions: High-side switch, Input protection, ESD protection, load dump and reverse battery protection , protection against loss of ground**

Type	BTS	442E2
Logic version		<b>E</b>
Overtemperature protection $T_j > 150\text{ °C}$ , latch function <sup>15)16)</sup> $T_j > 150\text{ °C}$ , with auto-restart on cooling		<b>X</b>
Short-circuit to GND protection switches off when $V_{ON} > 8.3\text{ V typ.}^{15)}$ (when first turned on after approx. 200 $\mu\text{s}$ )		<b>X</b>
Open load detection in OFF-state with sensing current 30 $\mu\text{A typ.}$ in ON-state with sensing voltage drop across power transistor		<b>X</b>
Undervoltage shutdown with auto restart		<b>X</b>
Overvoltage shutdown with auto restart		<b>X</b>
Status feedback for		
overtemperature		<b>X</b>
short circuit to GND		<b>X</b>
short to $V_{bb}$		- <sup>17)</sup>
open load		<b>X</b>
undervoltage		-
overvoltage		-
Status output type		
CMOS		
Open drain		<b>X</b>
Output negative voltage transient limit (fast inductive load switch off)		
to $V_{bb} - V_{ON(CL)}$		<b>X</b>
Load current limit		
high level (can handle loads with high inrush currents)		<b>X</b>
medium level		
low level (better protection of application)		

<sup>15)</sup> Latch except when  $V_{bb} - V_{OUT} < V_{ON(SC)}$  after shutdown. In most cases  $V_{OUT} = 0\text{ V}$  after shutdown ( $V_{OUT} \neq 0\text{ V}$  only if forced externally). So the device remains latched unless  $V_{bb} < V_{ON(SC)}$  (see page 4). No latch between turn on and  $t_{d(SC)}$ .

<sup>16)</sup> With latch function. Reseted by a) Input low, b) Undervoltage, c) Overvoltage

<sup>17)</sup> Low resistance short  $V_{bb}$  to output may be detected by no-load-detection

## Timing diagrams

Figure 1a:  $V_{bb}$  turn on:

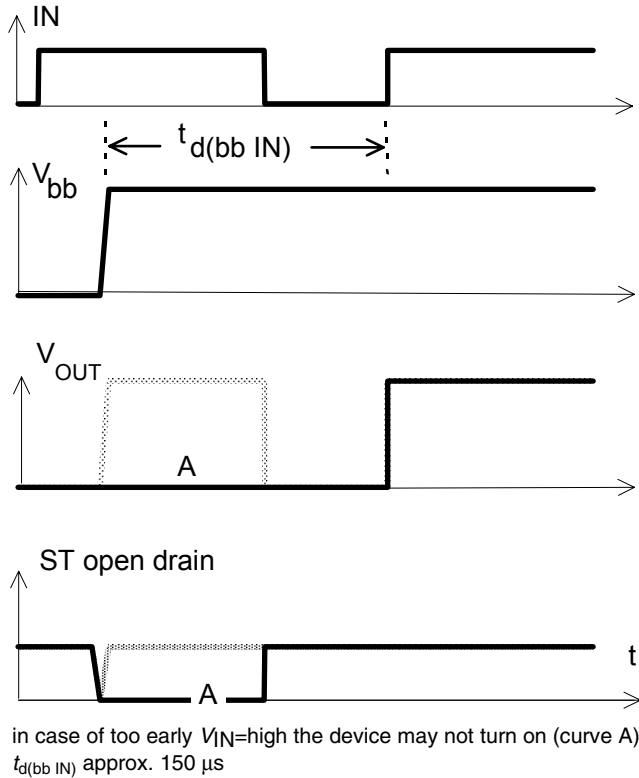

Figure 2a: Switching a lamp,

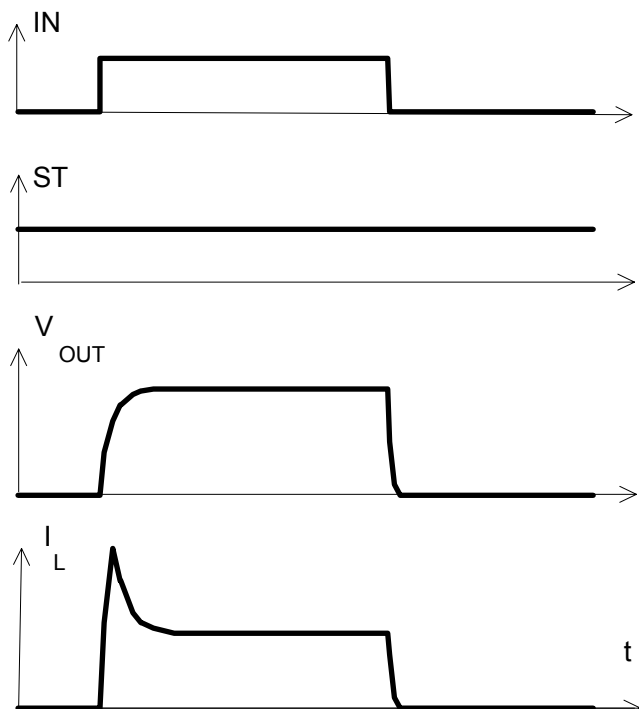

Figure 2b: Switching an inductive load

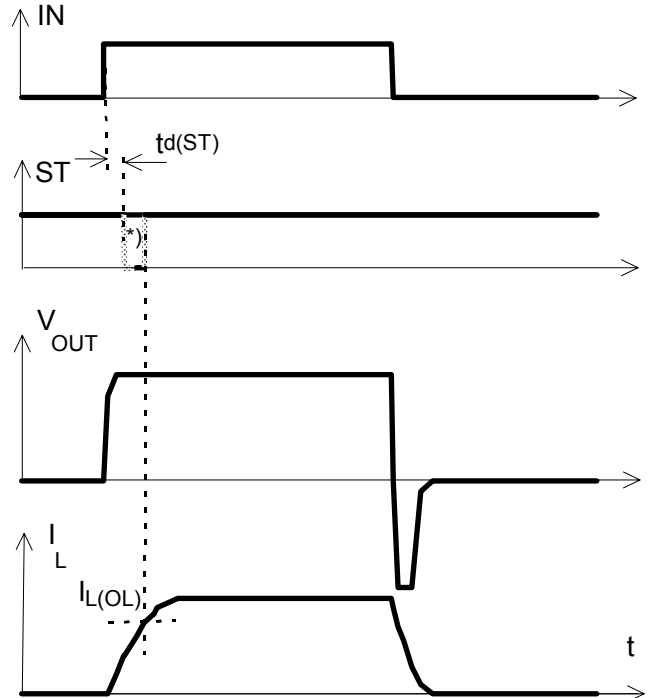
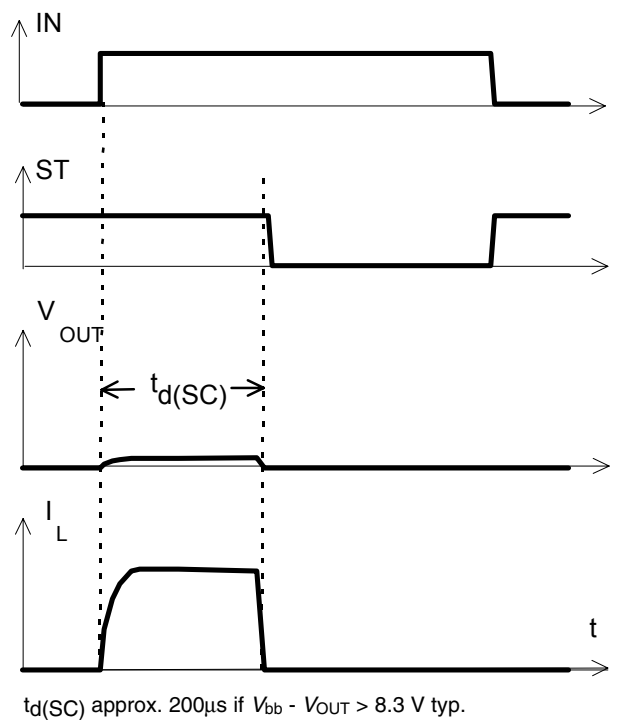
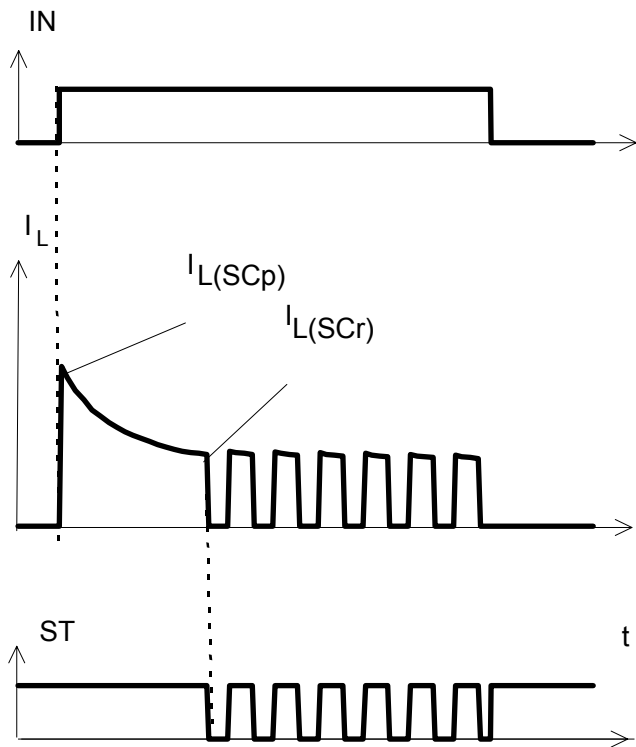

Figure 3a: Turn on into short circuit,

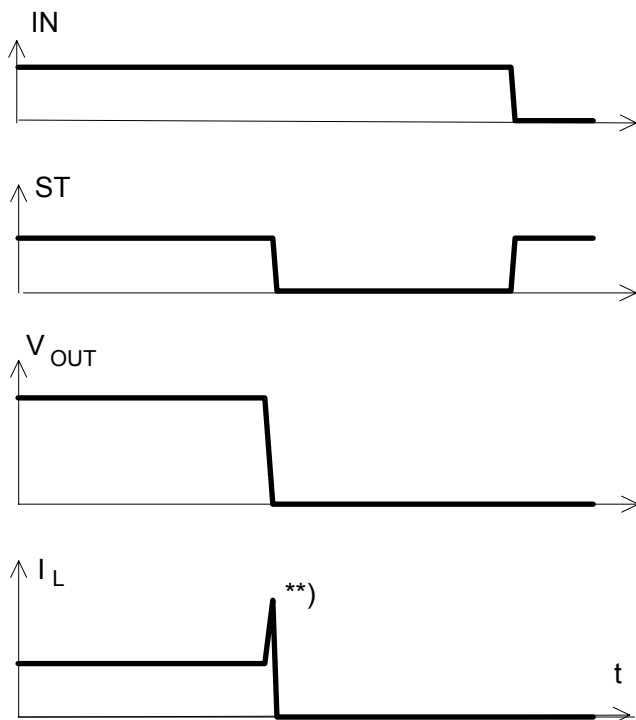

**Figure 3b:** Turn on into overload,



Heating up may require several milliseconds,  
 $V_{bb} - V_{OUT} < 8.3$  V typ.

**Figure 3c:** Short circuit while on:



\*\*)) current peak approx. 20 μs

**Figure 4a:** Overtemperature:  
 Reset if  $T_j < T_{jt}$

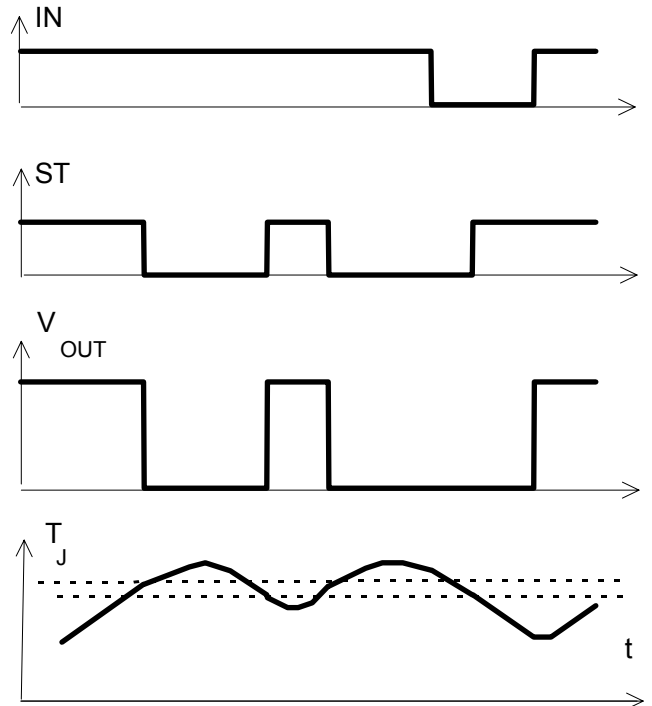

**Figure 5a:** Open load: detection in ON-state, turn on/off to open load

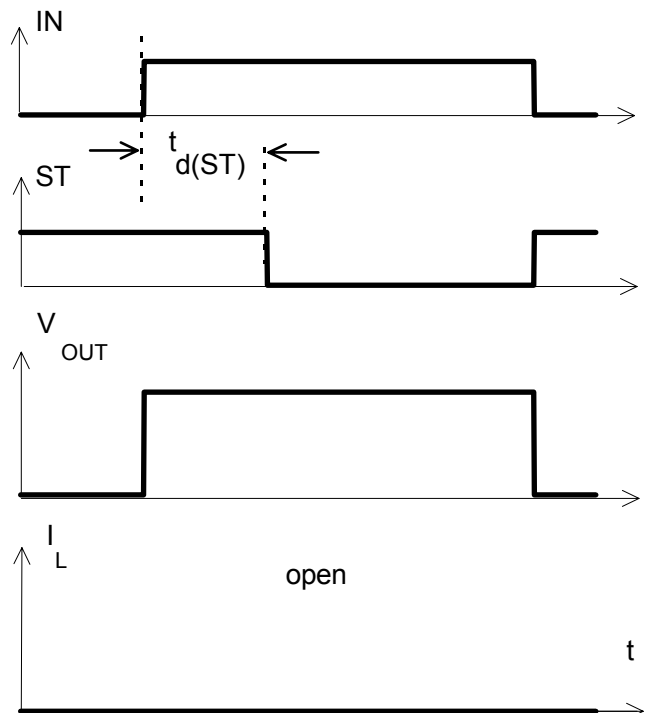

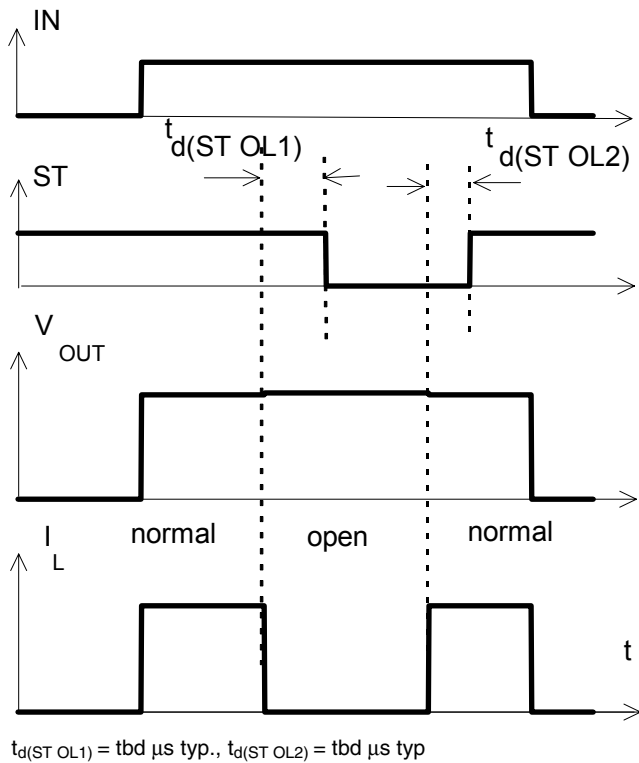
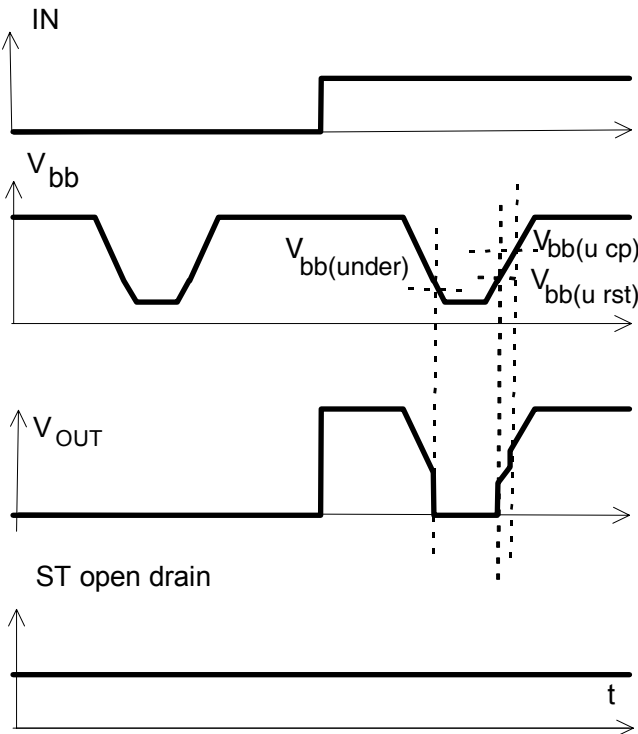
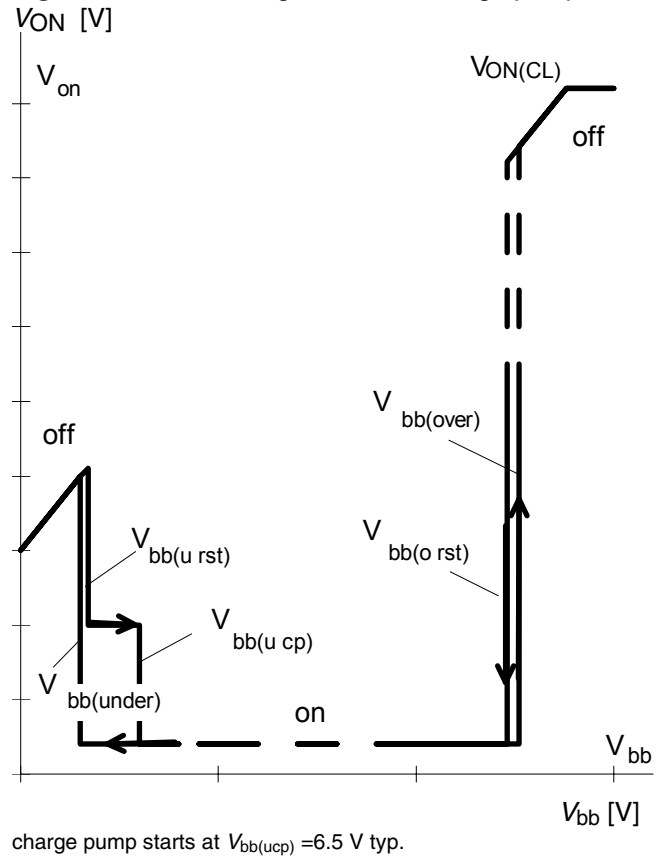
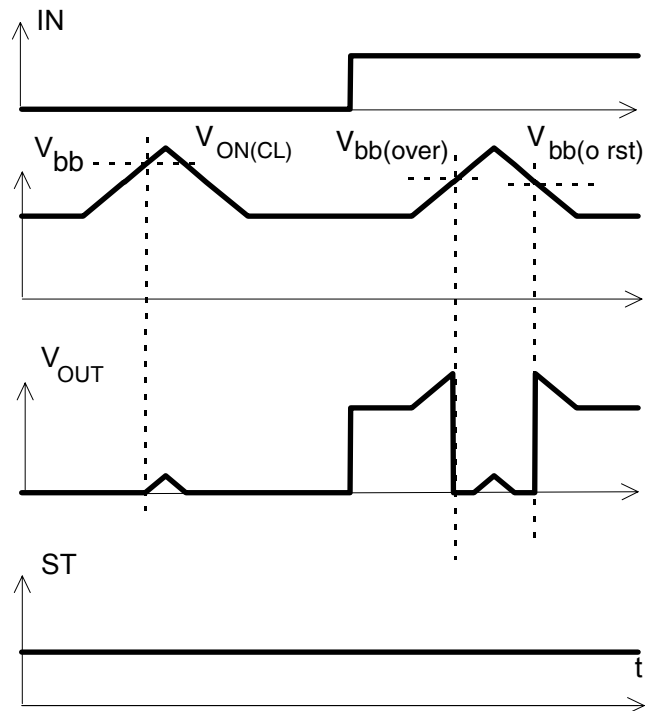
**Figure 5b:** Open load: detection in ON-state, open load occurs in on-state

**Figure 6a:** Undervoltage:

**Figure 6b:** Undervoltage restart of charge pump

**Figure 7a:** Overvoltage:

## Package and Ordering Code

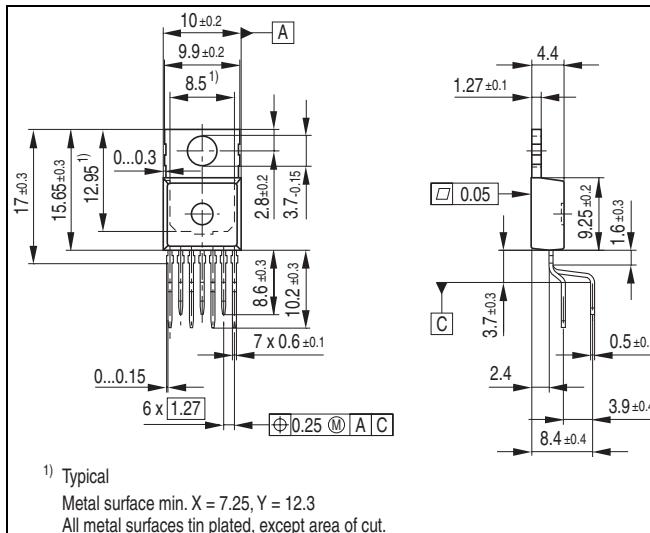
All dimensions in mm

### PG-TO220-5-11

BTS 442 E2
------------



### SMD PG-TO263-5-2

BTS442E2 E3062A
-----------------

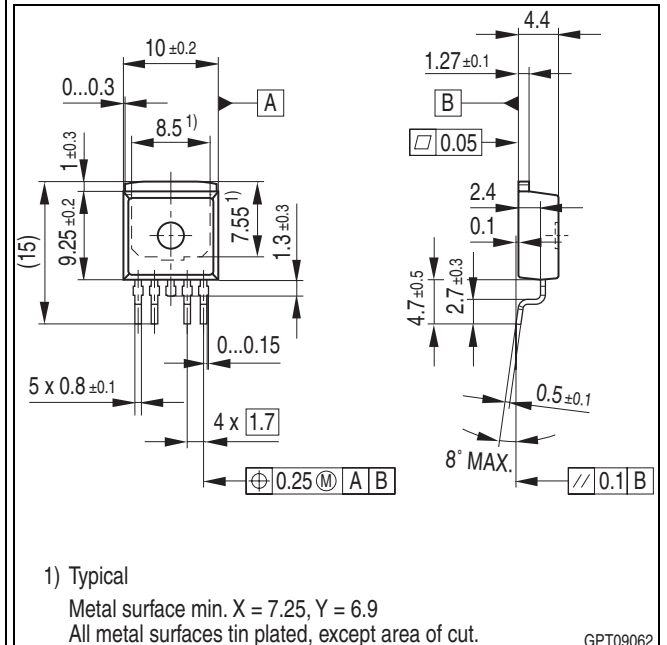

### Green Product

To meet the world-wide customer requirements for environmentally friendly products and to be compliant with government regulations the device is available as a green product. Green products are RoHS-Compliant (i.e Pb-free finish on leads and suitable for Pb-free soldering according to IPC/JEDEC J-STD-020).

## Revision History

Version	Date	Changes
Rev. 1.0	2009-11-12	RoHS-compliant version of BTS442E2 Removal of straight lead package variant E3043 Page 1, page 13: RoHS compliance statement and Green product feature added Page 1, page 13: Change to RoHS compliant packages; PG-TO220-5-11 for standard (staggered) variant; PG-TO263-5-2 for E3062A variant. Page 2: Thermal resistance junction to ambient for SMD version set to typically 33K/W. Page 2: Pin marking removed. Page 6, 9: Discontinued variants removed from truth table & options overview. Legal disclaimer updated

**Published by**  
**Infineon Technologies AG**  
**81726 Munich, Germany**  
**© 2009 Infineon Technologies AG**  
**All Rights Reserved.**

**Legal Disclaimer**

The information given in this document shall in no event be regarded as a guarantee of conditions or characteristics. With respect to any examples or hints given herein, any typical values stated herein and/or any information regarding the application of the device, Infineon Technologies hereby disclaims any and all warranties and liabilities of any kind, including without limitation, warranties of non-infringement of intellectual property rights of any third party.

**Information**

For further information on technology, delivery terms and conditions and prices, please contact the nearest Infineon Technologies Office ([www.infineon.com](http://www.infineon.com)).

**Warnings**

Due to technical requirements, components may contain dangerous substances. For information on the types in question, please contact the nearest Infineon Technologies Office.  
Infineon Technologies components may be used in life-support devices or systems only with the express written approval of Infineon Technologies, if a failure of such components can reasonably be expected to cause the failure of that life-support device or system or to affect the safety or effectiveness of that device or system. Life support devices or systems are intended to be implanted in the human body or to support and/or maintain and sustain and/or protect human life. If they fail, it is reasonable to assume that the health of the user or other persons may be endangered.