

	1	2	3	4	5	6	7																																	
A					<p><b>Material</b> Zinc die-cast</p> <p><b>Delivery includes</b></p> <table border="0"> <tr> <td>1</td> <td>half-sheets</td> <td>(2x)</td> </tr> <tr> <td>2</td> <td>knurled screws</td> <td>(2x)</td> </tr> <tr> <td>3</td> <td>screw</td> <td>(1x)</td> </tr> <tr> <td>4</td> <td>half shells of strain relief</td> <td>(8x)</td> </tr> </table>		1	half-sheets	(2x)	2	knurled screws	(2x)	3	screw	(1x)	4	half shells of strain relief	(8x)	<p><b>SPECIFICATION</b></p> <p><b>MATERIAL</b></p> <p><b>Features</b></p> <p><b>Material and finish</b> Zinc-die-cast,nickel plated</p> <p><b>Temperature range</b> -40° to +120°</p> <p>④ <b>Cable diameter</b> 4.0mm - 13.0mm</p> <p><b>Attenuation factor</b> &gt;40 dB between 30Mhz and 1Ghz</p> <p><b>Requirements</b> VDE 0871,FCC 20780, 89/336/EU</p>		A																			
1	half-sheets	(2x)																																						
2	knurled screws	(2x)																																						
3	screw	(1x)																																						
4	half shells of strain relief	(8x)																																						
B									B																															
C									C																															
D									D																															
E									E																															
F									F																															
G							<table border="1"> <thead> <tr> <th></th> <th>Date</th> <th>Name</th> <th>Title</th> </tr> </thead> <tbody> <tr> <td>Drawn</td> <td>18.12.04</td> <td>Ken</td> <td rowspan="2">AMET-15 RS</td> </tr> <tr> <td>Approved</td> <td>25.09.08</td> <td>W.Hellwig</td> </tr> <tr> <td>④ changed cable Ø</td> <td>21.09.2015</td> <td>A. Plate</td> <td></td> </tr> <tr> <td>③ update of detailed specification. added sheets</td> <td>28.02.2014</td> <td>A. Siozios</td> <td></td> </tr> <tr> <td>② Sheet 2 added</td> <td>25.09.08</td> <td>N.Schulz</td> <td></td> </tr> <tr> <td>① drawing revised</td> <td>04.07.07</td> <td>N.Schulz</td> <td></td> </tr> <tr> <td>Modification</td> <td>Date</td> <td>Name</td> <td></td> </tr> </tbody> </table>			Date	Name	Title	Drawn	18.12.04	Ken	AMET-15 RS	Approved	25.09.08	W.Hellwig	④ changed cable Ø	21.09.2015	A. Plate		③ update of detailed specification. added sheets	28.02.2014	A. Siozios		② Sheet 2 added	25.09.08	N.Schulz		① drawing revised	04.07.07	N.Schulz		Modification	Date	Name		G
	Date	Name	Title																																					
Drawn	18.12.04	Ken	AMET-15 RS																																					
Approved	25.09.08	W.Hellwig																																						
④ changed cable Ø	21.09.2015	A. Plate																																						
③ update of detailed specification. added sheets	28.02.2014	A. Siozios																																						
② Sheet 2 added	25.09.08	N.Schulz																																						
① drawing revised	04.07.07	N.Schulz																																						
Modification	Date	Name																																						
H							<table border="1"> <tr> <td colspan="2">Drawing-No.</td> <td>Sheet</td> </tr> <tr> <td colspan="2">ASS 0420 CO</td> <td>rev04</td> </tr> <tr> <td colspan="2">Replace</td> <td>Sheet 2/5</td> </tr> </table>		Drawing-No.		Sheet	ASS 0420 CO		rev04	Replace		Sheet 2/5	H																						
Drawing-No.		Sheet																																						
ASS 0420 CO		rev04																																						
Replace		Sheet 2/5																																						
	1	2	3	4	5	6	7																																	

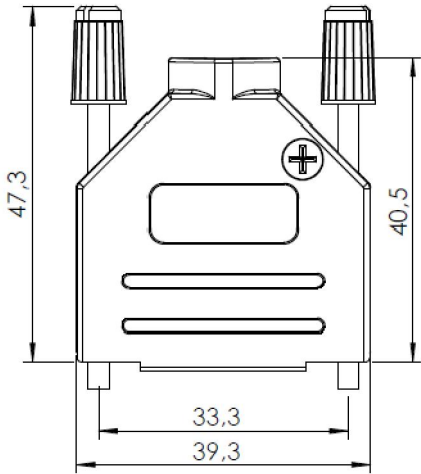
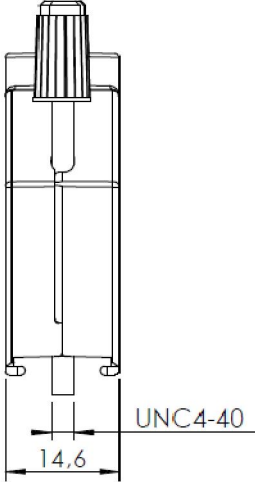
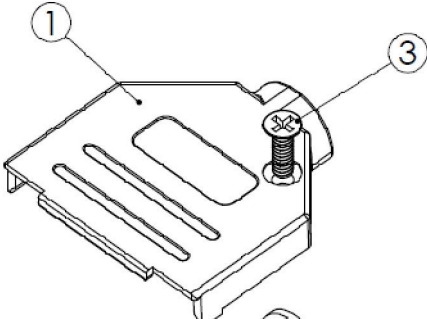
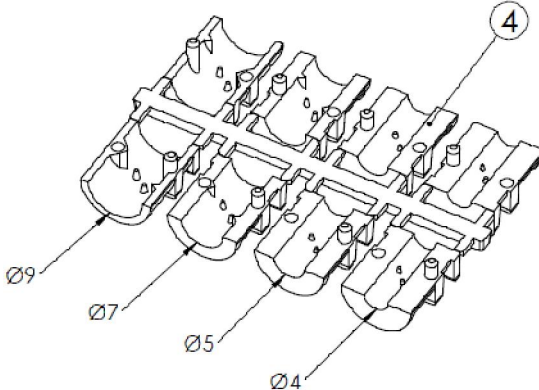
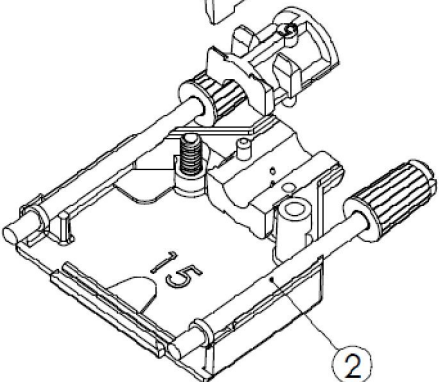