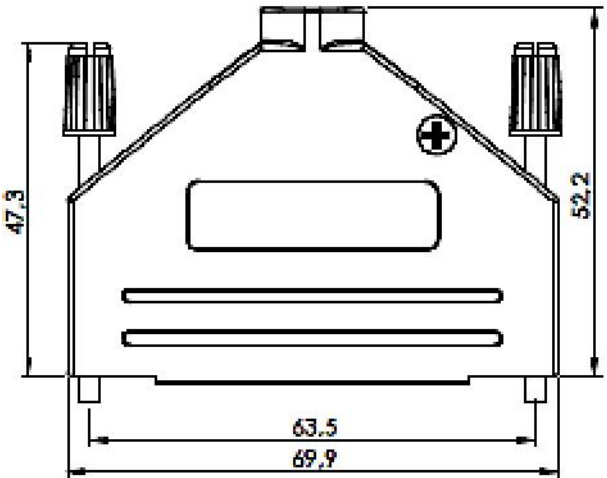
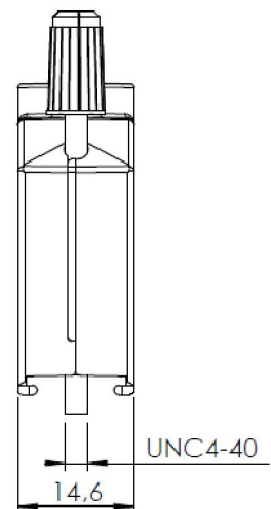
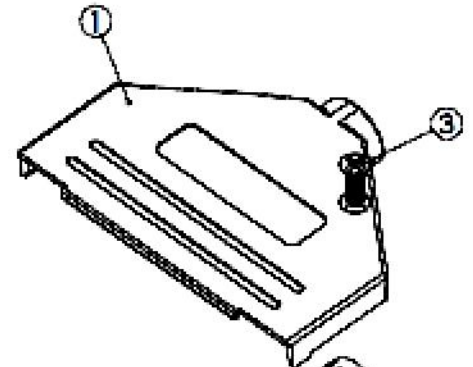
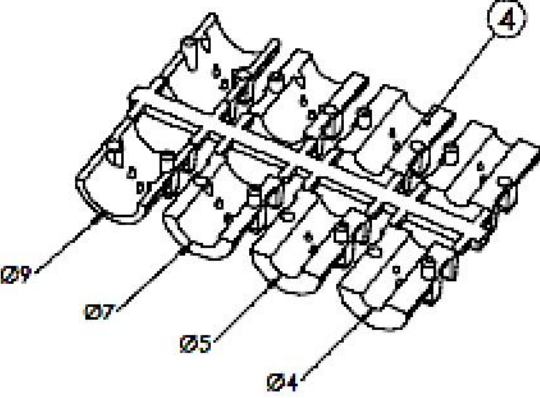
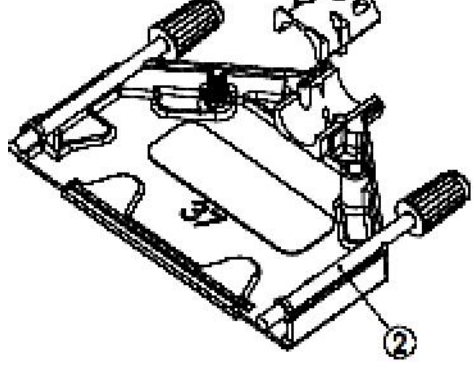

	1	2	3	4	5	6	7																																																		
A				<p>Material Zinc die-cast</p> <p>Delivery includes</p> <table border="0"> <tr> <td>1</td> <td>half-sheets</td> <td>(2x)</td> </tr> <tr> <td>2</td> <td>knurled screws</td> <td>(2x)</td> </tr> <tr> <td>3</td> <td>screw</td> <td>(1x)</td> </tr> <tr> <td>4</td> <td>half shells of strain relief</td> <td>(8x)</td> </tr> </table>	1	half-sheets	(2x)	2	knurled screws	(2x)	3	screw	(1x)	4	half shells of strain relief	(8x)	<p>SPECIFICATION</p> <p>MATERIAL</p> <p>Features</p> <p>Material and finish Zinc-die-cast, nickel plated</p> <p>Temperature range -40° to +120°</p> <p>Cable diameter ④ 4.0mm - 13.0mm</p> <p>Attenuation factor >40 dB between 30Mhz and 1Ghz</p> <p>Requirements VDE 0871, FCC 20780, 89/336/EU</p>			A																																					
1	half-sheets	(2x)																																																							
2	knurled screws	(2x)																																																							
3	screw	(1x)																																																							
4	half shells of strain relief	(8x)																																																							
B								B																																																	
C								C																																																	
D								D																																																	
E								E																																																	
F								F																																																	
G			<table border="1"> <thead> <tr> <th></th> <th></th> <th></th> <th></th> <th>Date</th> <th>Name</th> <th>Title</th> </tr> </thead> <tbody> <tr> <td></td> <td></td> <td></td> <td></td> <td>Drawn</td> <td>18.12.04</td> <td>Ken</td> </tr> <tr> <td>④</td> <td>changed cable Ø</td> <td>21.09.2015</td> <td>A. Plate</td> <td>Approved</td> <td>25.09.08</td> <td>W.Hellwig</td> </tr> <tr> <td>③</td> <td>update of detailed specification, added sheets</td> <td>28.02.2014</td> <td>A. Siozios</td> <td></td> <td></td> <td></td> </tr> <tr> <td>②</td> <td>Sheet 2 added</td> <td>25.09.08</td> <td>N.Schulz</td> <td></td> <td></td> <td></td> </tr> <tr> <td>①</td> <td>drawing revised</td> <td>04.07.07</td> <td>N.Schulz</td> <td></td> <td></td> <td></td> </tr> <tr> <td></td> <td>Modification</td> <td>Date</td> <td>Name</td> <td></td> <td></td> <td></td> </tr> </tbody> </table>								Date	Name	Title					Drawn	18.12.04	Ken	④	changed cable Ø	21.09.2015	A. Plate	Approved	25.09.08	W.Hellwig	③	update of detailed specification, added sheets	28.02.2014	A. Siozios				②	Sheet 2 added	25.09.08	N.Schulz				①	drawing revised	04.07.07	N.Schulz					Modification	Date	Name				<p>AMET-09 RS</p>	G
				Date	Name	Title																																																			
				Drawn	18.12.04	Ken																																																			
④	changed cable Ø	21.09.2015	A. Plate	Approved	25.09.08	W.Hellwig																																																			
③	update of detailed specification, added sheets	28.02.2014	A. Siozios																																																						
②	Sheet 2 added	25.09.08	N.Schulz																																																						
①	drawing revised	04.07.07	N.Schulz																																																						
	Modification	Date	Name																																																						
H						<p>Drawing-No.</p> <p>ASS 0420 CO</p> <p>Replace</p>	<p>Sheet</p> <p>rev04</p> <p>Sheet 4/5</p>	H																																																	
	1	2	3	4	5	6	7																																																		

	1	2	3	4	5	6	7																	
A									A															
B															B									
C															C									
D															D									
E						<table border="1"> <tr> <td>Plastic knop</td> <td>Plating</td> </tr> <tr> <td>Black</td> <td>Black</td> </tr> </table>		Plastic knop	Plating	Black	Black	E												
Plastic knop	Plating																							
Black	Black																							
F						<table border="1"> <tr> <td colspan="2">Thread</td> </tr> <tr> <td>A</td> <td>Plating</td> </tr> <tr> <td>UNC4-40</td> <td>Zink</td> </tr> </table>		Thread		A	Plating	UNC4-40	Zink	F										
Thread																								
A	Plating																							
UNC4-40	Zink																							
G						<table border="1"> <tr> <td></td> <td>Date</td> <td>Name</td> <td>Title</td> </tr> <tr> <td></td> <td>18.12.04</td> <td>Ken</td> <td rowspan="3">AMET-xx RS</td> </tr> <tr> <td>④</td> <td>21.09.2015</td> <td>A. Plate</td> <td>Approved</td> </tr> <tr> <td>③</td> <td>28.02.2014</td> <td>A. Siozios</td> <td></td> </tr> </table>			Date	Name	Title		18.12.04	Ken	AMET-xx RS	④	21.09.2015	A. Plate	Approved	③	28.02.2014	A. Siozios		G
	Date	Name	Title																					
	18.12.04	Ken	AMET-xx RS																					
④	21.09.2015	A. Plate		Approved																				
③	28.02.2014	A. Siozios																						
H						<table border="1"> <tr> <td>②</td> <td>25.09.08</td> <td>N.Schulz</td> <td rowspan="2">Drawing-No. ASS 0420 CO</td> <td>Sheet rev04</td> </tr> <tr> <td>①</td> <td>04.07.07</td> <td>N.Schulz</td> <td>Replace</td> <td>Sheet 5/5</td> </tr> </table>		②	25.09.08	N.Schulz	Drawing-No. ASS 0420 CO	Sheet rev04	①	04.07.07	N.Schulz	Replace	Sheet 5/5	H						
②	25.09.08	N.Schulz	Drawing-No. ASS 0420 CO	Sheet rev04																				
①	04.07.07	N.Schulz		Replace	Sheet 5/5																			
	1	2	3	4	5	6	7																	