

**11366**

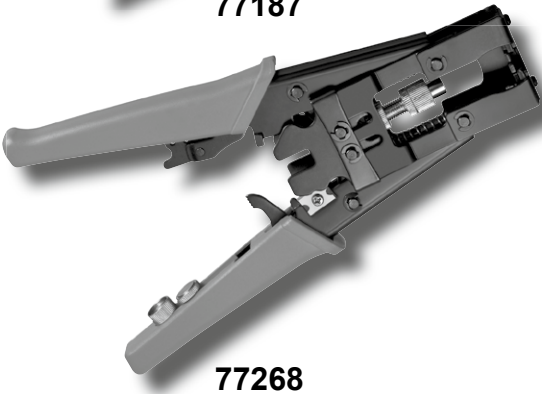

**77187**



**77268**

*Crimping pliers*

## Fixpoint® - Crimping Pliers



**ATTENTION! Read the manual completely and carefully. It is part of the product and contains important advices for correct implementing and use. Retain this manual for availability when passing to other persons and if there are further questions.**

### Content:

### Page:

1	Safety Instructions	8
2	Description and Function	9
3	Intended Use	9
4	Scope of Delivery	9
5	Field of Application and Configuration	9
6	Construction	10
7	Instructions	10
8	Cutting, Stripping and Crimping	11
9	Care, Maintenance, Storage and Transport	11
10	Troubleshooting	12
11	Warranty and liability	12
12	Specifications	13
13	Disposal Notes	13

### 1 Safety Instructions:



**ATTENTION! Demounting of the product is only permitted to skilled mechanics!**



**ATTENTION! Risk of injury by bruises!**

Never hold limbs between moveable product parts!

- This product is no toy and children must not use it anyway, because it contains fragile, small and swallowable parts such as mechanics, which can bruise or cut people with incorrect use!
- Remove and dispose packaging materials, because playing children could cut on it. Furthermore there is a danger of swallowing and inhaling of incidentals and insulating of materials.
- Do not interrupt the product to extreme heat, coldness or direct sun insulation.
- Lock the tool after use, if a lock is included.
- Work under good light conditions to minimize the risk of injuries.
- Do not modify or alter the device or its accessories! Therefor mind chapter "warranty and liability".

- Furthermore avoid liquid or dust effects.
- If defects, mechanical damages, disturbances or other problems occur, which are not solvable with this manual, take the device out of work immediately and consult your dealer for questions, repairing or change like it is described in chapter "warranty and liability".
- Mind the specifications for transporting and use applicable methods for it, e.g. by transporting in the original packaging.
- Do not use any damaged parts.
- Please attend to the terms of use in chapter 3.
- Don't put limbs between movable parts to avoid brusing and cutting.

## 2 Description and Function:

This product is a crimping plier for connecting different plug types to unshielded or shielded cables, depending on the model. Depending on the model it is useable for different plug types and can cut and strip cables. Pliers with ratch come with finishing mechanism and emergency release.

## 3 Intended Use:

This product is provided for using like described in chapter 1. It is only allowed to use it in dry interior rooms. Disregarding and non-compliance of these terms and of the Notes on Safety may cause massive accidents and damages to people and things.

## 4 Scope of Delivery:

- 1 pc. crimping tool
- 1 pc. user's manual

## 5 Field of Application and Configuration:

11366	BNC, TNC, SMA, N	+ useable for RG 55, 58, 59, 62, 140, 141, 142, 210, 223, 303 and 400 + Ratchet + Crimping diameter: 6.5/5.41/1.72 mm + lock mechanism and ratch
77187	RG 59 (4C9), RG 6 (5C)	+ for F compression plugs + lock mechanism and ratch
77268	F, BNC, IEC, RCA	+ automatic Stop + ratchet with auto lock + incl. 3 adaptors + ratch

GB

## 6 Construction:

11366:

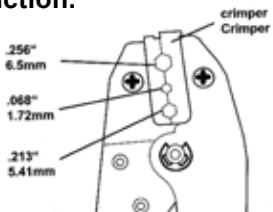

77187:

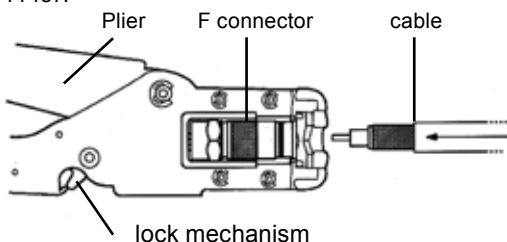

77268:

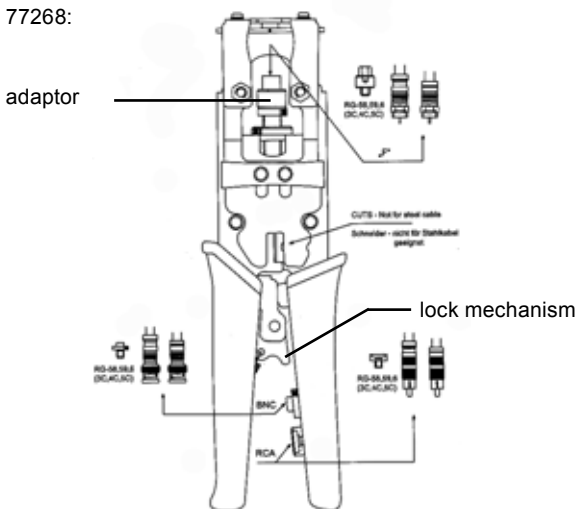

Front view



Ejection:

closed

open

## 7 Instructions:

- The crimping plier must be in correct and cleaned

condition before starting work.

- Remove crimping residues from cheeks and plier after each crimping.
- Protect the angles from dirt and grease them regularly with light machine oil.

## 8 Cutting, Stripping and Crimping:

- If a cutter and stripper is included, cut cables by putting it into the tool from the labeled site and compress the tool until opening automatically.

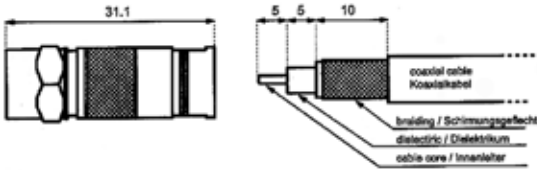

1. Strip the cable in a way, until app. 5-10 mm of the inner conductor, app. 5-10 mm dielectric and app. 10 mm of the shielding are visible.

*By using a compression plug or at too loose fitting, the stripping lengths may be varied and the shielding may be put over the cable jacket, to get fixed fitting.*

2. Turn the plug onto the cable as close as possible until fitting well.
3. Insert the cable into the crimping plier together with the plug.
4. Close the ejection at the front site, if included.
5. Adjust the plier until no tolerance is detectable.
6. Press together the crimping plier closely.
7. Unlock the plier, when necessary. Remove cable and plug from the crimping plier.

## 9 Care, Maintenance, Storage and Transport:

- Clean the product only with a dry and soft cloth. Be careful with cleaning to avoid scratches. For intensive Staining you can damp the cloth with some water. Do not use cleaning supplies and chemicals, because they can corrode the plastic material.
- Remove residues with a small knife carefully.
- Store your product in a dry and dustproof surround when not used for longer time. The product must be stored impenetrable for children.
- Retain the packaging to avoid damages during transport.
- Protect the angles from dirt and grease them regularly with light machine oil.

## 10 Troubleshooting:

Problem	Help
The tool does not open.	Compress the tool strongly until opening automatically.
	Open a trapped tool by using the emergency release by turning the small wheel or by pressing.
	Unlock the tool like described in chapter "Construction".
bad crimping	Mind orthogonal and complete putting in the cable.
	Strip the cable and compress the tool.
	Remove residues from the tool.
other questions	Consult your dealer.

## 11 Warranty and Liability:

- The producer grants a 2 years guarantee to a new device.
- As the manufacturer has no influence on installation, warranty of the product only applies to the product itself.
- If any fault or damage is detected on your device, please contact your dealer and provide your sales slip or invoice as evidence of the purchase, if necessary. Your dealer will repair the fault either on site, or send the device to the manufacturer. You make the work of our technicians considerably easier, when you describe possible faults in detail – only then you can be assured that faults occurring only rarely will be found and repaired with certainty!
- The manufacturer is not liable for damages to persons or property caused by improper installation or operation not described in this guide. This includes, among others, any alteration and modification of the product and its accessories.
- Any use other than described in this user's guide is not permitted, and causes loss of warranty, loss of guarantee, and non-liability.
- We reserve our right for misprints and changes of the device, packing, or user's guide.

## 12 Specifications:

Model	11366	77187	77268
dimensions (mm)	215 x 65 x 20	210 x 80 x 25	223 x 65 x 22
weight (g)	464	455	469
plug type	BNC, TNC, SMA, N	RG 59 (4C9, RG 6 (5C)	F, BNC, IEC, Cinch

## 13 Disposal Notes:

This product should not be disposed together with domestic waste. Please return your device free of charge at the end of its service life at public collection points established for this purpose, or at the sales outlet. Details for disposal are regulated in the relevant federal state law. Potential recyclable materials are fed into the recycling cycle to obtain new raw materials from them. Following recyclable materials are collected at local collection points:

- Waste glass, plastic, waste metal, metal sheet, and more.

This type of recycling of waste equipment contributes significantly to the protection of our environment.