

SWITCH CIRCUIT

WHEN CARD IS EJECTED

WHEN CARD IS INSERTED

CLOSE

OPEN

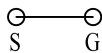

MATERIAL AND FINISH AS BELOW

A	Housing	LCP+30% G/F	E	Drag Link	Stainless Steel SUS304
B	Contact	Phosphor Bronze C5210-EH, Contact Area:10u * Gold Plating	F	Spring	Piano Wire
C	Shell	Stainless Steel SUS304R-3/4H, Solder Area:Gold Flash	G	Switch	Phosphor Bronze C5191-H, Contact Area:Gold Flash
D	Slider	LCP+30% G/F	H		

- NOTES:
- DATE CODE 0202 (YWWDD)  
Y:0 YEAR(2010)  
WW:20 WEEK(01-52)  
D:2 DAY(01-07)
  - 0202 WIDE x HIGH(6mm x 2mm)

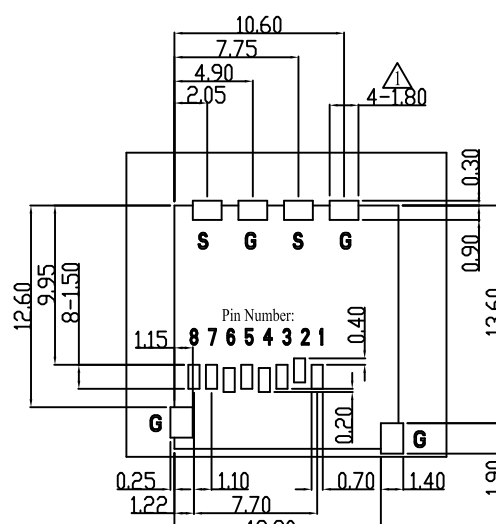
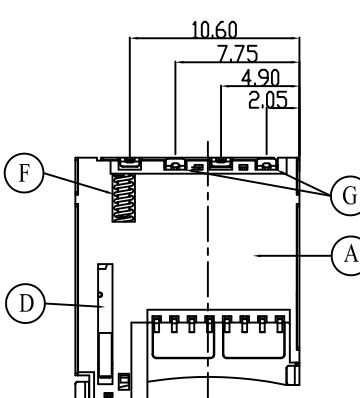
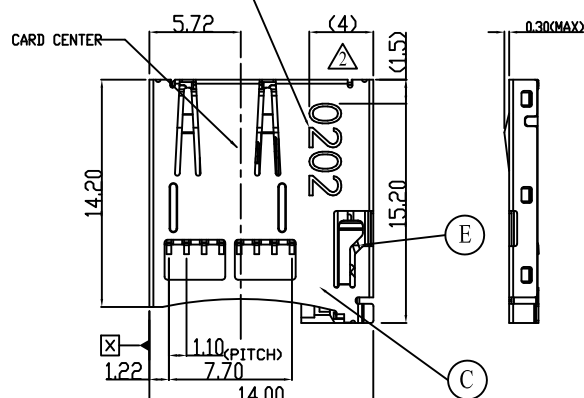

SPECIFICATION:

- ELECTRICAL
  - Current Rating: 0.5A per pin
  - Voltage Rating: 100V AC/DC
  - Contact Resistance: 50mΩ
  - Insulation Resistance: 1000mΩ
  - Dielectric Withstanding Voltage: 500VAC
- MECHANICAL
  - Durability: 10000 Cycle
  - Insertion Force: 9.8N max.
  - Extraction Force: 9.8N max.
- ENVIRONMENTAL
  - Operating temperature range: -40°C~+90°C
  - Storage temperature range: -40°C~+90°C
- SOLDER ABILITY
  - Recommended IR Reflow Temperature: 260°C
  - Recommended PCB Thickness: 1.0mm

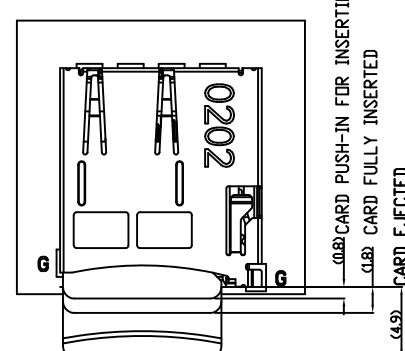
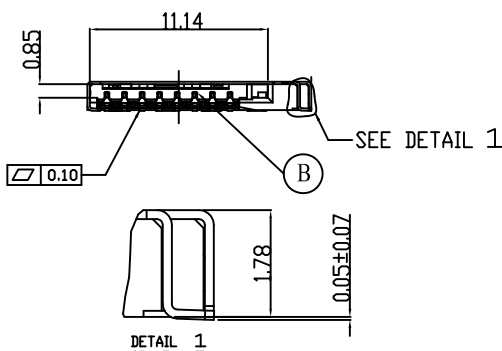

DAT2	CD/DAT3	CMD	VDD	CLK	VSS	DAT0	DAT1	DETECTION	GND
P1	P2	P3	P4	P5	P6	P7	P8	S	G

PIN ASSIGNMENT

112A-TAAR-R02	Top Mount, Push-Push Type, Contact Area: 10u * Gold Plating
PRODUCT NO.	DESCRIPTION

UNLESS OTHERWISE SPECIFIED TOLERANCE		
ANGLES	ANG.	±5°
LINEAR	0.	±0.3
	0.0	±0.25
	0.00	±0.20
SCALE	AS SHOWN	UNIT: mm
DRAWN	Willis	2012/08/03
CHECKED	Angel	2012/08/03
APPROVED	Ken	2012/08/03

www.attend.com.tw

DRAWN NAME: Micro SD Socket Top Mount, Push-Push Type

PRODUCT NO. 112A-TAAR-R02

FILE NAME 112A-TAAR-R02\_B\_5

3	Revise: Change Drawing	2012/03/13
2	Revise: Date Code	2010/05/24
1	Revise: 2-1.80 Change to 4-1.80 Dimensions	2010/01/05

REV.	DESCRIPTION	DATE	REV.	DESCRIPTION	DATE	SIZE	REV.	FILE NAME
1						A4	1.0	112A-TAAR-R02_B_5

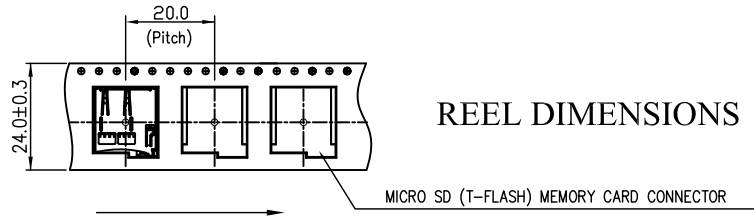

**REEL DIMENSIONS**

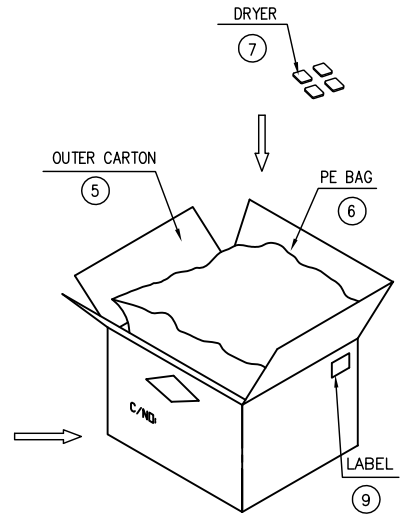
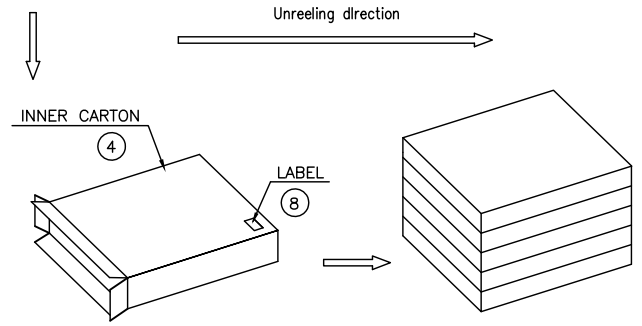
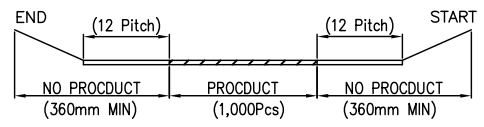
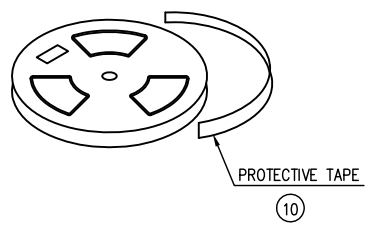
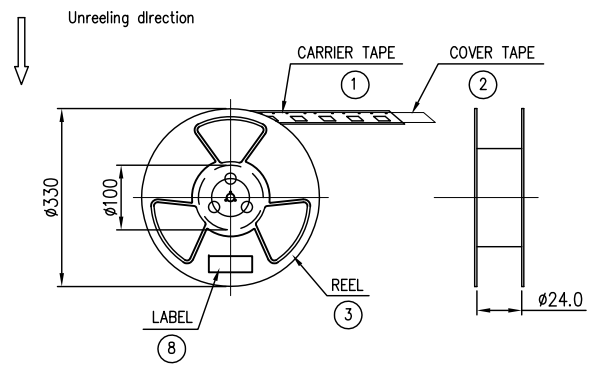

**PACKAGING SPECIFICATION:**

- 1. MATERIAL**
  - 1.1 Embossed Carrier Tape: PS Black
  - 1.2 Top Cover Tape: PET  
20-80g(Peel Speed 300mm/Minute)
  - 1.3 Taping Reel: Plastic
- 2. PACKING**
  - 2.1 Quantity:
    - 1000Piece/Reel
    - 2Reel/Inner Carton
    - 10000Piece/Outer Carton
  - 2.2 Net Weight: 10Kg
  - 2.3 Gross Weight: 11Kg/Carton

15		
14		
13		
12		
11		
10	PROTECTIVE TAPE	
9	LABEL	
8	LABEL	
7	DRYER	
6	PE BAG	L850*W750mm
5	OUTER CARTON	
4	INNER CARTON	
3	REEL	φ 330*100mm,W=24mm
2	COVER TAPE	W=21.5mm,20.8M
1	CARRIER TAPE	W=24mm,T=0.30mm,20.8M/REEL
NO.	PACKING NAME	DESCRIPTION

				UNLESS OTHERWISE SPECIFIED TOLERANCE			 www.attend.com.tw		
ANGLES		ANG.		±5°					
LINEAR		0.		±0.3					
		0.00		±0.25					
SCALE		AS SHOWN		UNIT: mm					
DRAWN		Willis		2012/08/03		DRAWN NAME:			
CHECKED		Angel		2012/08/03		Micro SD Socket Top Mount,Push-Push Type			
APPROVED		Ken		2012/08/03		PRODUCT NO.		112A-TAAR-R02	
REV.	DESCRIPTION	DATE	REV.	DESCRIPTION	DATE	SIZE	REV.	FILE NAME	
1						A4	1.0	112A-TAAR-R02_D_3	

A

A

A

A

A

A

# EMBOSED CARRIER TAPE DIMENSIONS

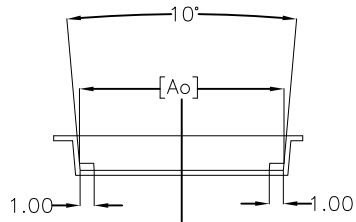
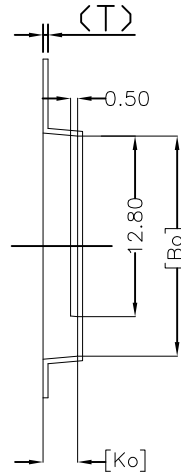
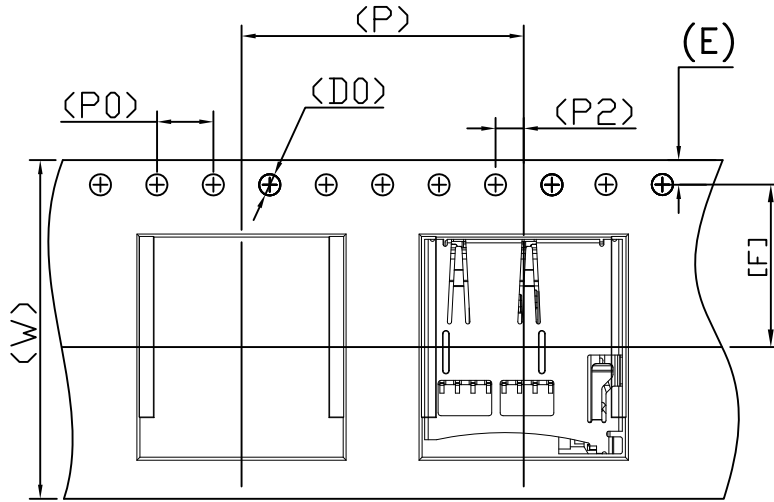

# PACKAGING SPECIFICATION:

- 1.Part Conforms to EIA-481-C Standards.
- 2.All dimensions in millimeters.
- 3.10 sprocket hole pitch cumulative
- 4.Carrier camber is within 1mm in 100mm.
- 5.Ao and Bo Measured on a plane 0.3mm above the bottom of the pocket.
- 6.Ko measured from a plane on the inside bottom of the pocket to top surface of the carrier.
- 7.Marterial: PS Black Polystyrene.
- 8.Component load per 13" reel:1000pcs/21.0M

W	24.00 <sup>+0.30</sup> <sub>-0.30</sub>	T	0.30±0.05	P2	2.00±0.10	Ao	14.45±0.10
E	1.75±0.10	P	20.00±0.10	Do	∅1.50 <sup>+0.10</sup> <sub>-0</sub>	Bo	15.60±0.10
F	11.50±0.10	Po	4.00±0.10	D1	∅1.50MIN	Ko	2.70±0.10

UNLESS OTHERWISE SPECIFIED TOLERANCE		
ANGLES	ANG.	±5°
LINEAR	0.	±0.3
	0.0	±0.25
	0.00	±0.20
SCALE	AS SHOWN	UNIT: mm
DRAWN	Willis	2012/08/03
CHECKED	Angel	2012/08/03
APPROVED	Ken	2012/08/03



www.attend.com.tw  
 DRAWN NAME: Micro SD Socket Top Mount, Push-Push Type

REV.	DESCRIPTION	DATE	REV.	DESCRIPTION	DATE
1			4		
2			5		
3			6		
4			7		
5			8		
6			9		
7			10		

REV.	DESCRIPTION	DATE	REV.	DESCRIPTION	DATE	SIZE	REV.	FILE NAME
1			4			A4	1.0	112A-TAAR-R02_D_3

Revise:  
 Revise:  
 Revise: Updated version

2011/09/06

PRODUCT NO. 112A-TAAR-R02

FILE NAME 112A-TAAR-R02\_D\_3