

**SURFACE MOUNT
THYRISTOR SURGE PROTECTIVE DEVICE**

Bi-Directional
VDRM - **58 to 360** Volts
IPP - **50** Amperes

FEATURES

- Oxide Glass Passivated Junction
- Bidirectional protection in a single device
- Surge capabilities up to 50A @ 10/1000us or 150A @ 8/20us
- High off state Impedance and low on state voltage
- Plastic material has UL flammability classification 94V-0

MECHANICAL DATA

- Case : Molded plastic
- Polarity : Denotes none cathode band
- Weight : 0.003 ounces, 0.093 grams

SMB

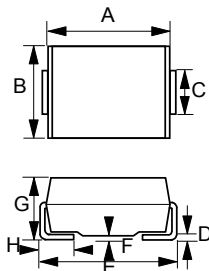

SMB		
DIM.	MIN.	MAX.
A	4.06	4.57
B	3.30	3.94
C	1.96	2.21
D	0.15	0.31
E	5.21	5.59
F	0.05	0.20
G	2.01	2.62
H	0.76	1.52

All Dimensions in millimeter

MAXIMUM RATINGS

CHARACTERISTICS	SYMBOL	VALUE	UNIT
Non-repetitive peak impulse current @ 10/1000us	IPP	50	A
Non-repetitive peak On-state current @ 8.3ms (one half cycle)	ITSM	25	A
Junction temperature range	TJ	-40 to +150	°C
storage temperature range	TSTG	-55 to +150	°C

THERMAL RESISTANCE

CHARACTERISTICS	SYMBOL	VALUE	UNIT
Junction to leads	Rth(J-L)	20	°C/W
Junction to ambient on print circuit (on recommended pad layout)	Rth(J-A)	100	°C/W
Typical positive temperature coefficient for brekdown voltage	$\Delta VBR/\Delta TJ$	0.1	%/°C

MAXIMUM RATED SURGE WAVEFORM

WAVEFORM	STANDARD	IPP (A)
2/10 us	GR-1089-CORE	150
8/20 us	IEC 61000-4-5	150
10/160 us	FCC Part 68	90
10/560 us	FCC Part 68	60
10/700 us	ITU-T K20/K21	55
10/1000 us	GR-1089-CORE	50

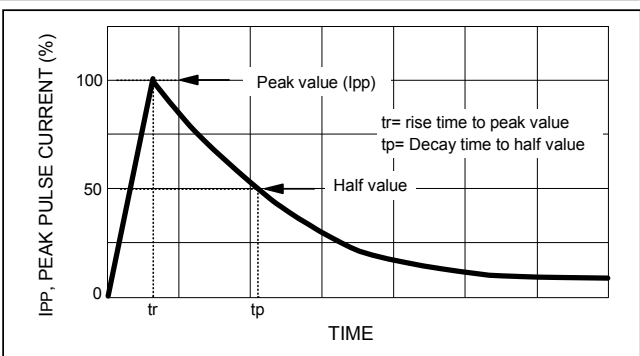

**ELECTRICAL CHARACTERISTICS @ TA= 25°C unless otherwise specified
TB0640L thru TB4000L**



PARAMETER	RATED REPETITIVE OFF-STATE VOLTAGE	OFF-STATE LEAKAGE CURRENT @ VDRM	BREAKOVER VOLTAGE	ON-STATE VOLTAGE @ IT=1.0A	BREAKOVER CURRENT		HOLDING CURRENT		OFF-STATE CAPACITANCE
					Min	Max	Min	Max	
SYMBOL	VDRM	IDRM	VBO	VT	IBO		IH		Co
UNITS	Volts	uA	Volts	Volts	mA		mA		pF
LIMIT	Max	Max	Max	Max	Min	Max	Min	Max	Typ
TB0640L	58	5	77	3.5	50	800	150	800	100
TB0720L	65	5	88	3.5	50	800	150	800	100
TB0900L	75	5	98	3.5	50	800	150	800	100
TB1100L	90	5	130	3.5	50	800	150	800	60
TB1300L	120	5	160	3.5	50	800	150	800	60
TB1500L	140	5	180	3.5	50	800	150	800	60
TB1800L	170	5	220	3.5	50	800	150	800	60
TB2300L	190	5	265	3.5	50	800	150	800	40
TB2600L	220	5	300	3.5	50	800	150	800	40
TB3100L	275	5	350	3.5	50	800	150	800	40
TB3500L	320	5	400	3.5	50	800	150	800	40
TB4000L	360	5	450	3.5	50	800	150	800	40

SYMBOL	PARAMETER
VDRM	Stand-off Voltage
IDRM	Leakage current at stand-off voltage
VBR	Breakdown voltage
IBR	Breakdown current
VBO	Breakover voltage
IBO	Breakover current
IH	Holding current Note: 1
VT	On state voltage
IPP	Peak pulse current
CO	Off state capacitance Note: 2

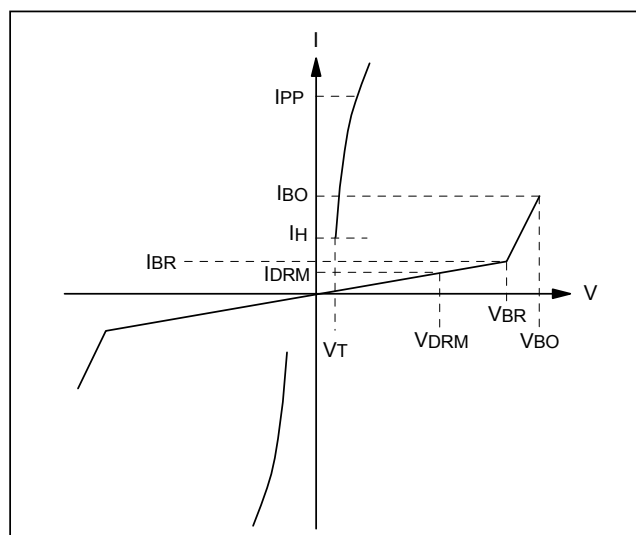

NOTES: 1. $I_H > (V_L/R_L)$ If this criterion is not obeyed, the TSPD Triggers but does not return correctly to high-resistance state. The Surge recovery time does not exceed 30ms.
2. Off-state capacitance measured at $f=1.0\text{MHz}$; 1.0VRMS signal; $V_R=2\text{VDC}$ bias.

FIG. 1 - OFF STATE CURRENT vs JUNCTION TEMPERATURE

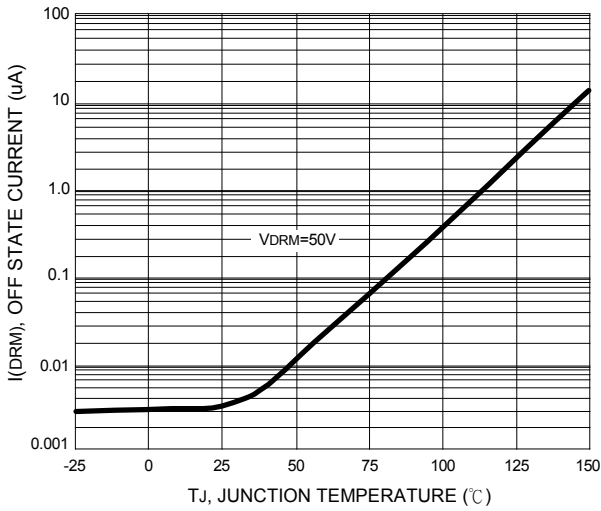

FIG. 2 - RELATIVE VARIATION OF BREAKDOWN VOLTAGE vs JUNCTION TEMPERATURE

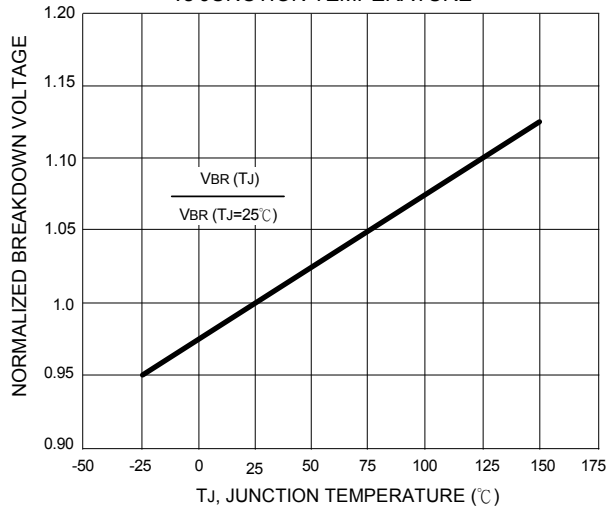

FIG. 3 - RELATIVE VARIATION OF BREAKOVER VOLTAGE vs JUNCTION TEMPERATURE

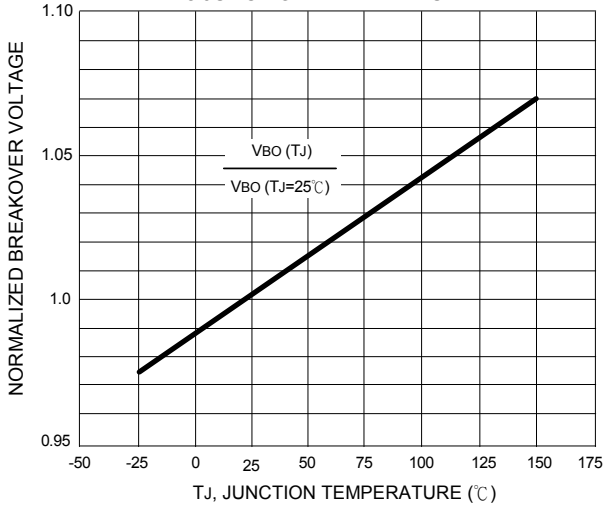

FIG. 4 - ON STATE CURRENT vs ON STATE VOLTAGE

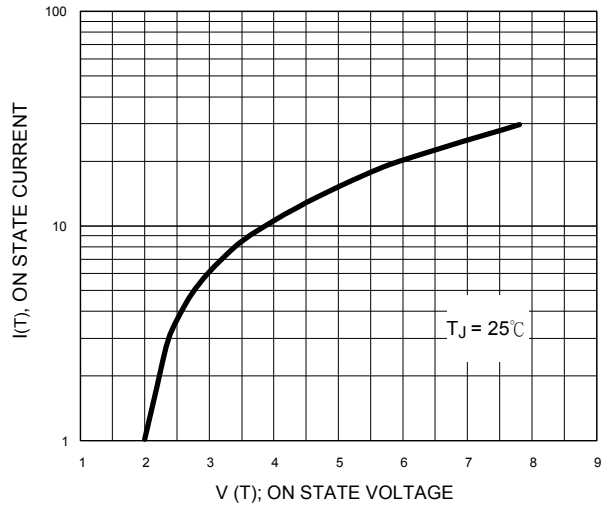

FIG. 5 - RELATIVE VARIATION OF HOLDING CURRENT vs JUNCTION TEMPERATURE

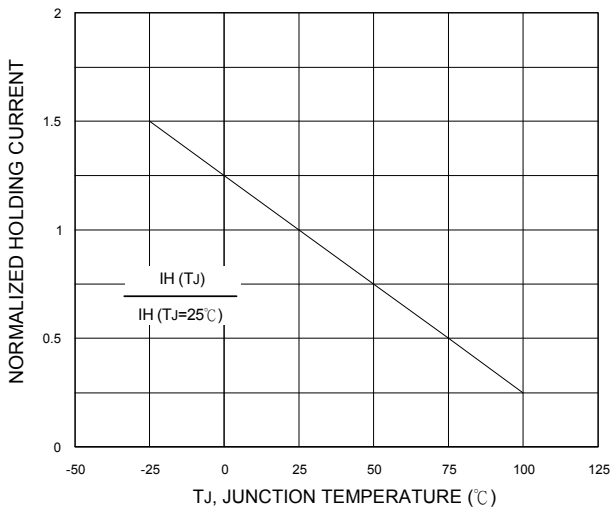
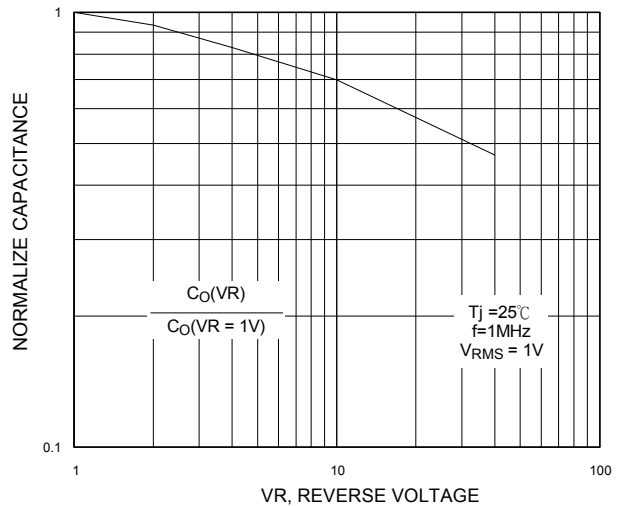
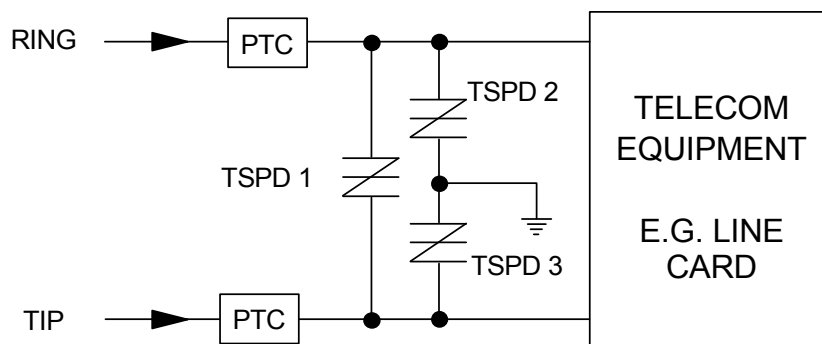
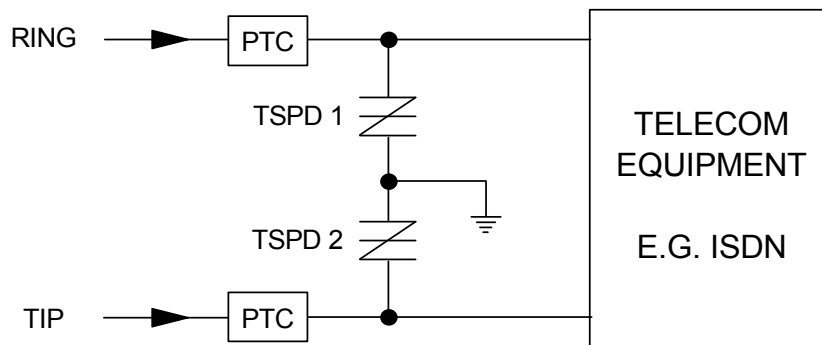
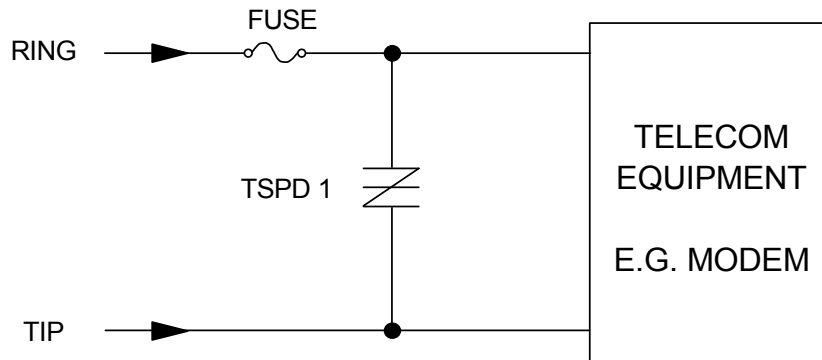

FIG. 6 - RELATIVE VARIATION OF JUNCTION CAPACITANCE vs REVERSE VOLTAGE BIAS





The PTC (Positive Temperature Coefficient) is an overcurrent protection device

Important Notice and Disclaimer

LSC reserves the right to make changes to this document and its products and specifications at any time without notice. Customers should obtain and confirm the latest product information and specifications before final design, purchase or use.

LSC makes no warranty, representation or guarantee regarding the suitability of its products for any particular purpose, nor does LSC assume any liability for application assistance or customer product design. LSC does not warrant or accept any liability with products which are purchased or used for any unintended or unauthorized application.

No license is granted by implication or otherwise under any intellectual property rights of LSC.

LSC products are not authorized for use as critical components in life support devices or systems without express written approval of LSC.