



HITPOINT

TEL:8862-26013311

FAX:8862-26013898

NO.4 Lane 505, Zhongzheng Rd., Linkou Shiang, Taipei, Taiwan 24445 . R.O.C

PS-532Q

(ROHS)

DATE:2004.12.28

1 . Electrical Characteristics

VER :0

Resonant Frequency (KHz)	2.3 ~3.5
Operating Voltage (Vdc)	7 ~ 15
Rated Voltage (Vdc)	12
Current Consumption (mA/max.)	200 at Rated Voltage
Sound Pressure Level (dB/min.)	105 at 100cm at Rated Voltage
Tone/Pulse Rate (Hz)	Hi/Low 1.2 ±20%
Operating Temperature (°C)	-20 ~ +70
Storage Temperature (°C)	-30 ~ +80
Manual soldering conditions	350±20°C / within 5sec

2 . Dimensions and Material

2-1 Shape

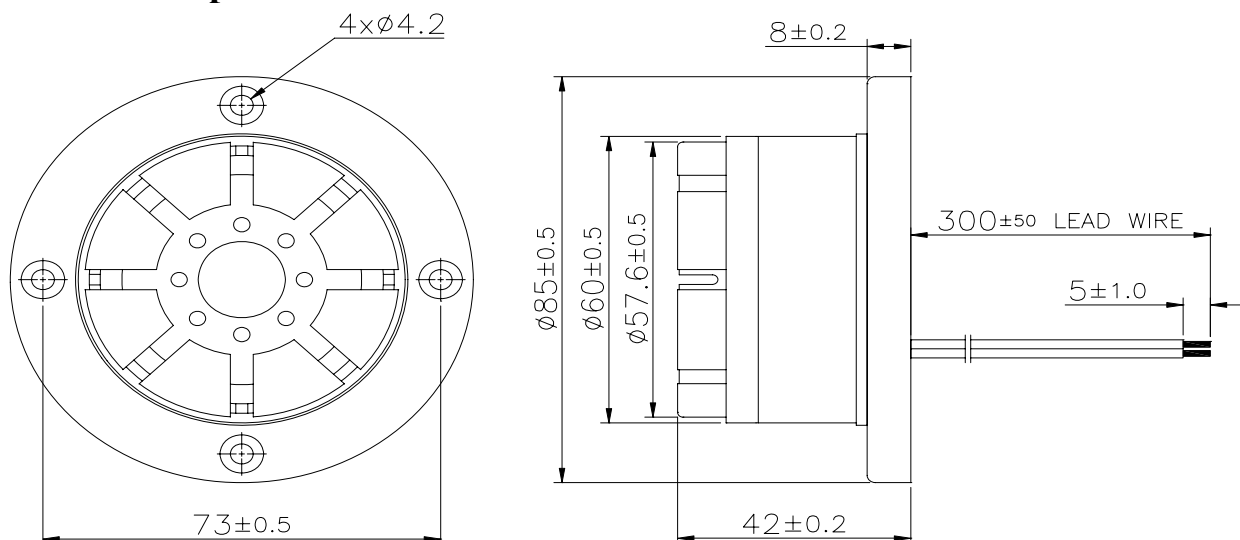

Unit : mm



HITPOINT

TEL:8862-26013311

FAX:8862-26013898

NO.4 Lane 505, Zhongzheng Rd., Linkou Shiang, Taipei, Taiwan 24445 . R.O.C

2-2 Material

Housing	ABS 757 UL94HB plastic resin (Color : Black)
Leading Wire	20 AWG
Weight (Gram)	79

3. TESTING METHOD

· *Standard Measurement conditions*

Temperature: $25 \pm 2^\circ\text{C}$ Humidity: 45-60%

· *Acoustic Characteristics*

The oscillation frequency, current consumption and sound pressure are measured by the measuring instruments shown below.

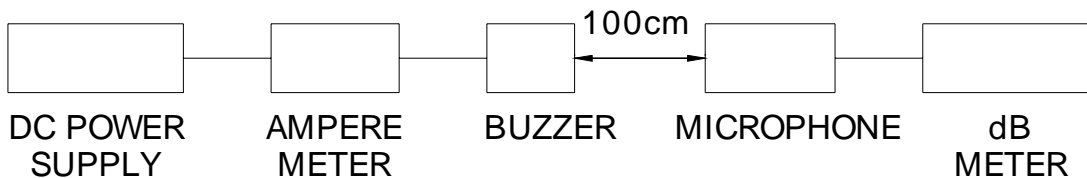

In the measuring test, buzzer is placed as follows:

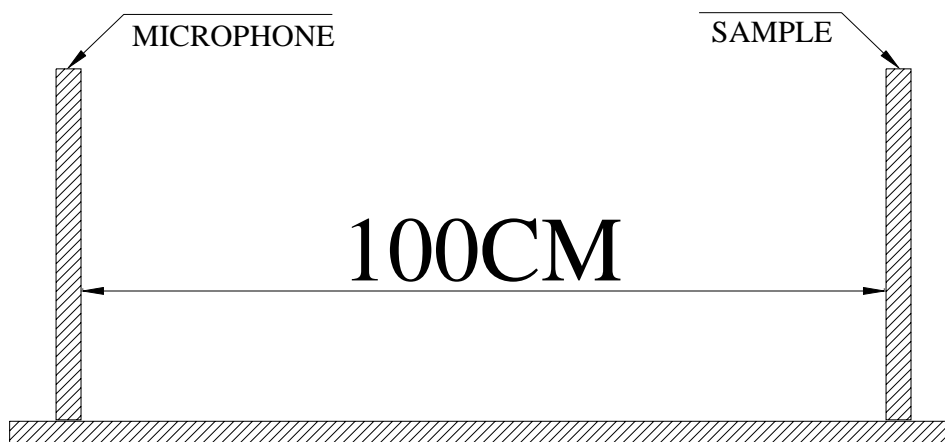

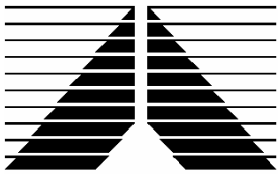

HITPOINT

TEL:8862-26013311

FAX:8862-26013898

NO.4 Lane 505, Zhongzheng Rd., Linkou Shiang, Taipei, Taiwan 24445 . R.O.C

4. RELIABILITY

ITEMS	METHOD OF TEST AND MEASUREMENTS	PERFORMANCE
<i>Coldness withstanding</i>	<i>After 98 hours of being exposed to -30°C environment, should be returned to normal environment for 2 hours, then re-proceed to test.</i>	<i>No abnormality shall exist</i>
<i>Hotness withstanding</i>	<i>After 98 hours of being exposed to +80°C environment, should be returned to normal environment for 2 hours, then re-proceed to test.</i>	<i>No abnormality shall exist</i>
<i>Humidity withstanding</i>	<i>After 98 hours of being exposed to 40°C 95%RH environment in actual operation, should be returned to normal environment for 2 hours, then re-proceed to test.</i>	<i>No abnormality shall exist</i>
<i>Vibration withstanding</i>	<i>Linear vibrate frequency rate: 5~55Hz Time:180sec , applied in X, Y and Z directions for 3 times each.</i>	<i>No abnormality shall exist</i>

5. PACKAGE METHOD

<1> 10pcs per box , Total 10 boxes per carton , total 100pcs carton;
Volume: L*W*H=510*330*300mm

< 2 > RoHS Mark

