

| 5 | 6 | 7 | 8 |
|------|---------|------|------|
| REV. | ECN NO. | DATE | SIGN |
| | | | |
| | | | |

THIS DOCUMENT IS SUBJECT TO CHANGE WITHOUT NOTICE. IT IS CONFIDENTIAL AND A PROPERTY OF LTW. DISCLOSURE TO THIRD PARTY HAS TO BE AUTHORIZED BY LTW.

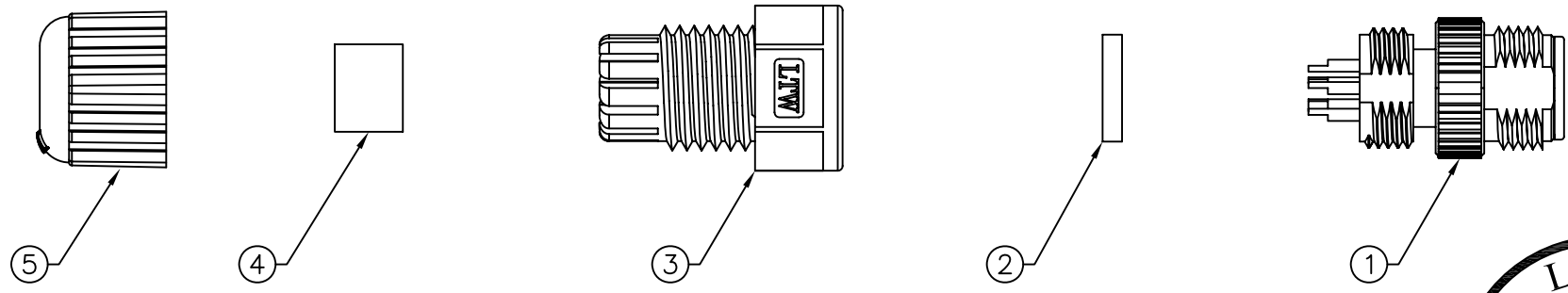

- Note:
- * Ⓞ Important Dimension To Check.
 - * Waterproof Rate: IP68
 - * Housing: Black, Nylon+GF
 - * Pin: Copper Alloy, Gold Plated
 - * Nut: Zinc Alloy, Nickel Plated
 - * Gasket: Black, EPDM
 - * Clamp Ring: Black, Nylon
 - * Sealing Nut: Black, Nylon
 - * Seals: Black, EPDM
 - * Seal For Cable OD: $\phi 4.5\text{mm} \sim \phi 6.5\text{mm}$

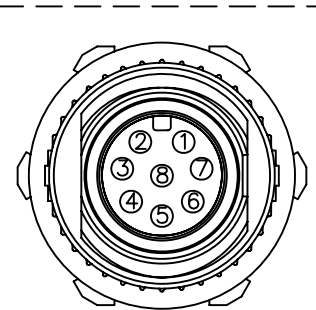
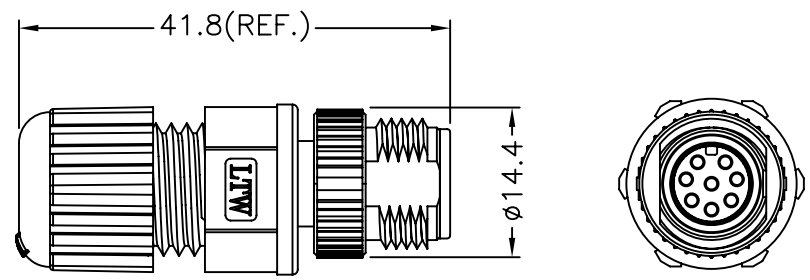

Pin Assignments
Front View

| | | | | | | | |
|-----------------------------------|---------------|---------------------------------------------------|------------------------------|----------------|--------------------------------|-------------------------|--------------------|
| UNIT:mm | | TITLE M12 Conn Assy Screw 8Pin M Conn M Pin | | 亮泰企業股份有限公司 | ITEM NO LTW12-08BMMASL8001 | DRAWN BY Jason Manas | DATE 2006/12/27 |
| TOLERANCE $\pm 0.5 \text{ mm}$ | SCALE Free | SHEET 1 OF 1 | DWG NO LTW12-08BMMASL8001 | | CHECKED BY Michael Cerenado | DATE 2006/12/28 | |
| REV. A | SIZE A4 | QC : Inspection Item | CUSTOMER | | APPROVED BY Max | DATE 2006/12/28 | |