

REV.	ECN NO.	DATE	SIGN	DESCRIPTION
B	LEN-750136	2007/05/09	Jason	Change Panel Cut-Out
C	LEN-7A0027	2007/09/29	Myrdal	Added Note

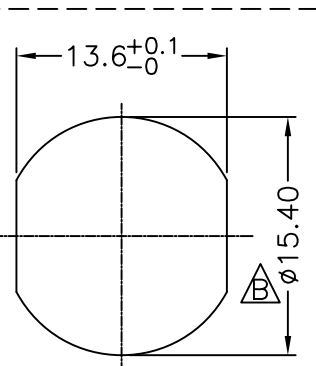

Recommended Panel Cut-Out

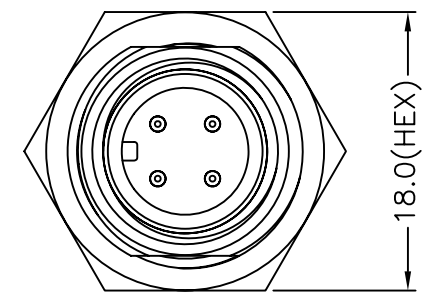
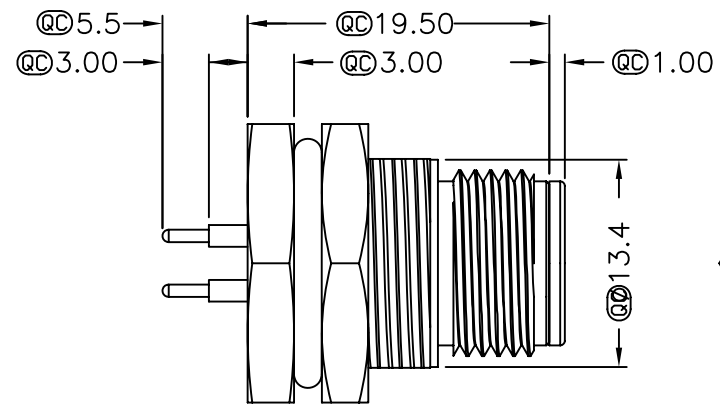
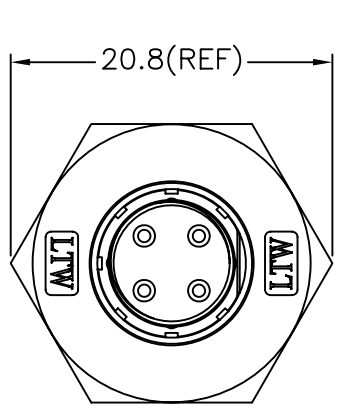
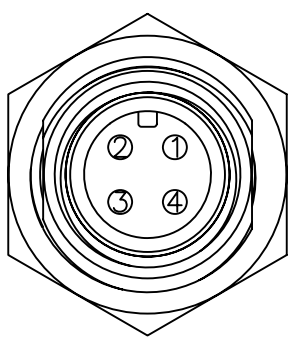

Pin Assignments Front View

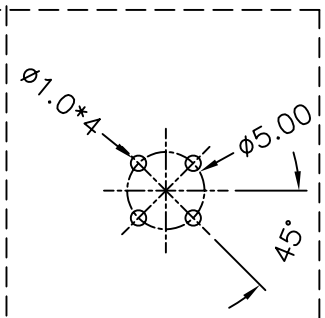

4Pin Male Connector Male Pin PCB Layout

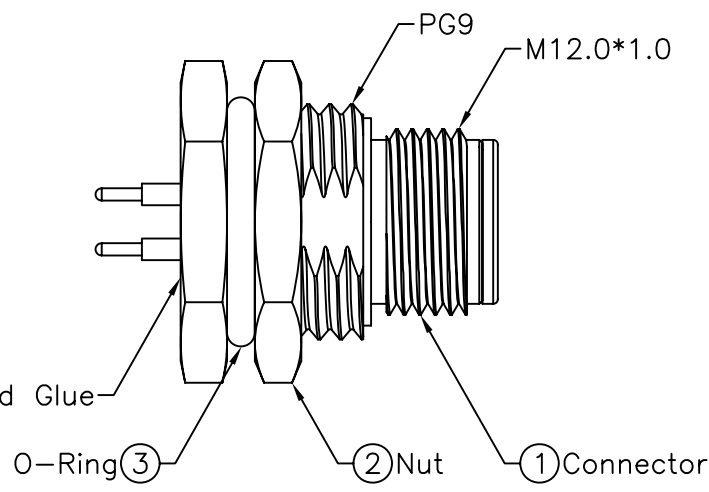

Note:

- \* @C Important Dimension.
- \* Waterproof Rate: IP68
- \* Housing: Black, Nylon+GF
- \* Male Pin: Copper Alloy, Gold Plated
- \* Shield: Zinc Alloy, Nickel Plated
- \* Nut: Zinc Alloy, Nickel Plated
- \* O-Ring: Black, EPDM
- \* For Panel Thickness Max 4.5mm
- \* Nut Torque: 4-6 kgf.cm

UNIT:mm	
TOLERANCE	
.X	±0.25
.XX	±0.1
.XXX	±0.05
ANGLES	±1°

TITLE	M12 Conn	
	Panel Screw 4Pin M Conn M Pin	
SCALE	Free	SHEET 1 OF 1
REV. C	SIZE A4	@C :Inspection Item

**LTW**  
亮泰企業股份有限公司

ITEM NO	LTW12-04PMMP-SF8001
DWG NO	LTW12-04PMMP-SF8001
CUSTOMER	

DRAWN BY	Myrdal Manzano
CHECKED BY	Alan MJ Sundo
APPROVED BY	Cloud

DATE	2007/09/29
DATE	2007/10/01
DATE	2007/10/04

THIS DOCUMENT IS SUBJECT TO CHANGE WITHOUT NOTICE. IT IS CONFIDENTIAL AND A PROPERTY OF LTW. DISCLOSURE TO THIRD PARTY HAS TO BE AUTHORIZED BY LTW.