

Dept	
Qty	
DC	1
ED	1
IE	1
ISO	1
PD	1
R&D	1
SD	1
QA	1
QC	1
QE	1

The information provided herein is from CONNPLY Electronic Co., Ltd. and is confidential. Any disclosure to a party other than the recipient is prohibited. The intellectual properties and its rights contained herein, including but not limited to, trademarks, patents, copyrights, trade secrets, and technical know-how, are owned exclusively by CONNPLY or its affiliates. Unauthorized use or modification is strictly prohibited without prior written consent from CONNPLY. All intellectual properties provided herein are for reference purposes only and does not constitute authorization of its use in any format or manner. CONNPLY may enforce its intellectual property rights at its own discretion; failures or delays to exercise such rights does not constitute a waiver of such rights.

REV.	DESCRIPTION	DRAWN	CHECKED	APPROVED
A	NEW RELEASE	LJH 09/20/05'		LJC 09/20/05'
B	ADD PACKING TYPE	JLZ 04/02/15'	HZW 04/02/15'	LJC 04/02/15'
C	DRAWING UPDATE	JLZ 08/24/18'		

HOUSING WITH CONTACT

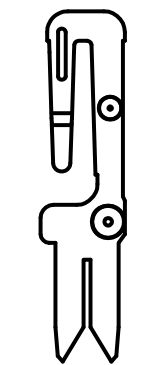
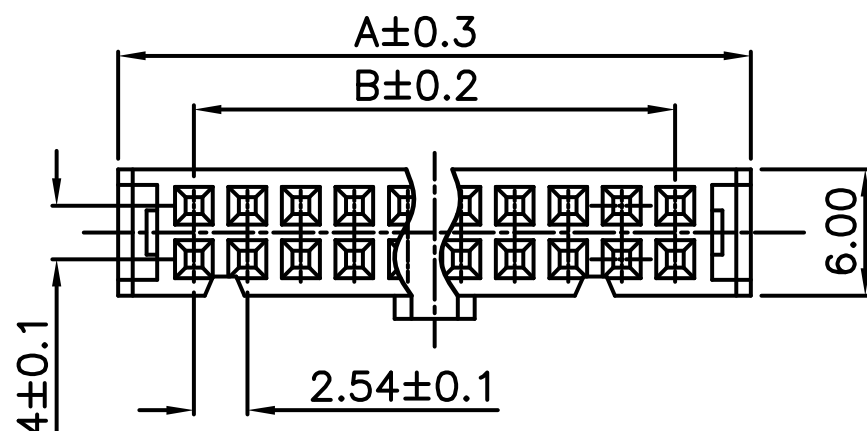

Contact Scale:2/1

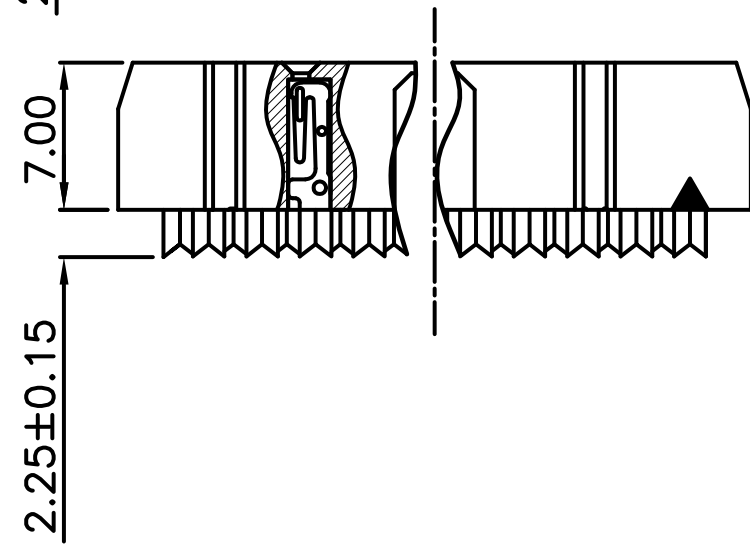

UPPER COVER

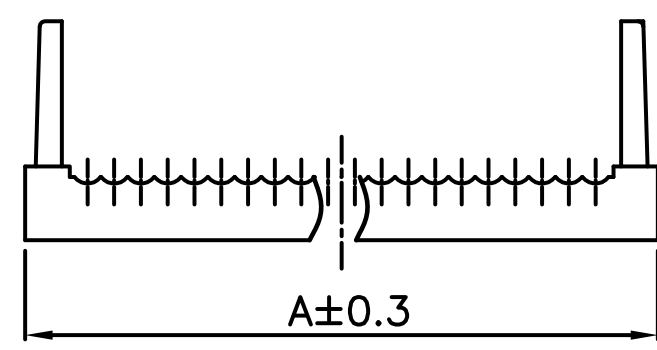
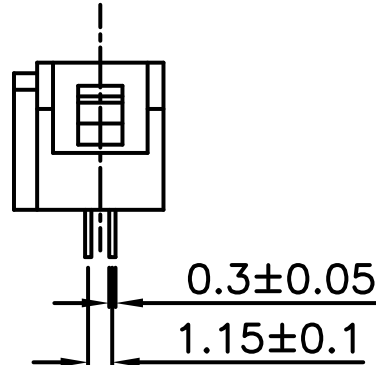

TOP COVER

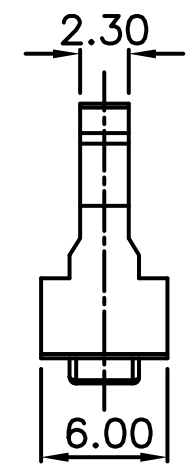
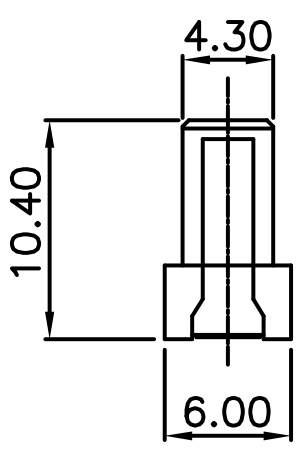
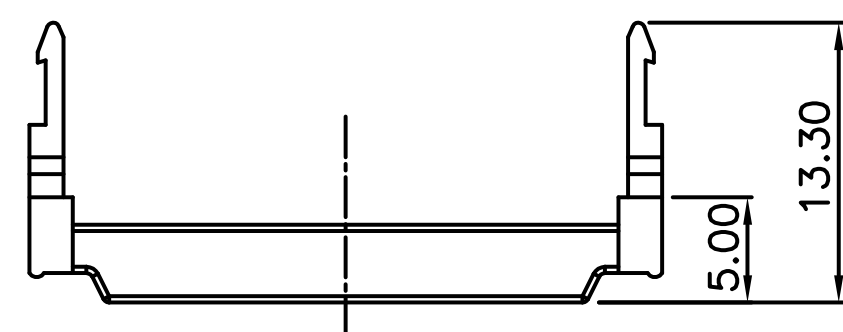

Position	Dimension	
	A	B
06	12.28	5.08
08	14.82	7.62
10	17.36	10.16
12	19.90	12.70
14	22.44	15.24
16	24.98	17.78
20	30.06	22.86
24	35.14	27.94
26	37.68	30.48
30	42.76	25.56
34	47.84	40.64
40	55.46	48.26
50	68.16	60.96
60	80.86	73.66
64	85.94	78.74

NOTES:

- ELECTRICAL CHARACTERISTICS:
 - CONTACT RESISTANCE: 20mΩ Max. INITIAL.
 - DIELECTRIC WITHSTANDING VOLTAGE: 500V AC(rms) FOR 1 MINUTE.
 - INSULATION RESISTANCE: 1000MΩ Min.
- ENVIRONMENT CHARACTERISTICS:
 - TEMPERATURE: -40°C~+105°C.
- PART NUMBER: DS1016
- PRODUCT NUMBER CODE:

DS1016- X X X X X X - X

- PACKING TYPE(TRAY)
2:ONE TRD+ONE TRU
N/A:MANY TRD+ONE TRU
- HOUSING COLOR
G:GRAY
B:BLACK
L:BLUE
- TERMINAL MATERIAL
B:BRASS
- CONTACT PLATING
8:FULL GOLD FLASH
2:Gold flash + Nickel
N:Full Nickel
- POLARIZATION
A:W/
B:W/O
- STRAIN RELIEF
M:W/
N:W/O
- No. OF CONTACTS
06 08 10 12 14
16 20 24 26 30
34 40 50 60 64

GENERAL TOLERANCE		ANGLE TOLERANCE		PROJECTION		TITLE	I.D.C SOCKET PITCH 2.54mm	
X.	±0.60	X.	±5°	UNITS	mm	SERIES	DS1016 SERIES	
.X	±0.38	.X	±3°	晨翔电子有限公司 CONNPLY® CONNPLY ELECTRONIC CO., LTD				
.XX	±0.25	.XX	±2°					
DRAWING TYPE		CUSTOMER						
SCALE		1:1	SHEET 1 OF 1					
DRAWING NO.		C-DS1016-XXXXXX-X-C						