



## Power Bridge Rectifiers

### SKD 30

#### Features

- Isolated metal case with screw terminals
- Blocking voltage up to 1600 V
- High surge currents
- Easy chassis mounting
- UL recognized, file no. E 63 532

#### Typical Applications\*

- Three phase rectifiers for power supplies
- Input rectifiers for variable frequency drives
- Rectifiers for DC motor field supplies
- Battery charger rectifiers
- Recommended snubber network:  
RC: 0.1  $\mu$ F, 50  $\Omega$  ( $P_R = 1$  W)

- 1) Freely suspended or mounted on an insulator
- 2) Mounted on a painted metal sheet of min. 250 x 250 x 1 mm

$V_{RSM}, V_{RRM}$ V	$V_{VRMS}$ V	$I_D = 30$ A ( $T_c = 98$ °C) Types	$C_{max}$ $\mu$ F	$R_{min}$ $\Omega$
200		SKD 30/02A1		0,15
400		SKD 30/04A1		0,3
800		SKD 30/08A1		0,5
1200		SKD 30/12A1		0,75
1400		SKD 30/14A1		0,9
1600		SKD 30/16A1		1

Symbol	Conditions	Values	Units
$I_D$	$T_a = 45$ °C, isolated <sup>1)</sup>	6,5	A
	$T_a = 45$ °C, chassis <sup>2)</sup>	15	A
$I_{DCL}$	$T_a = 45$ °C, isolated <sup>1)</sup>	6,5	A
	$T_a = 45$ °C, chassis <sup>2)</sup>	15	A
	$T_a =$ °C,		A
$I_{FSM}$	$T_{vj} = 25$ °C, 10 ms	370	A
	$T_{vj} = 150$ °C, 10 ms	320	A
$i^2t$	$T_{vj} = 25$ °C, 8,3 ... 10 ms	680	A <sup>2</sup> s
	$T_{vj} = 150$ °C, 8,3 ... 10 ms	500	A <sup>2</sup> s
$V_F$	$T_{vj} = 25$ °C, $I_F = 150$ A	max. 2,2	V
$V_{(TO)}$	$T_{vj} = 150$ °C	max. 0,85	V
$r_T$	$T_{vj} = 150$ °C	max. 12	m $\Omega$
$I_{RD}$	$T_{vj} = 25$ °C, $V_{RD} = V_{RRM}$	300	$\mu$ A
	$T_{vj} =$ °C, $V_{RD} = V_{RRM} \geq V$		$\mu$ A
$I_{RD}$	$T_{vj} = 150$ °C, $V_{RD} = V_{RRM}$	5	mA
	$T_{vj} =$ °C, $V_{RD} = V_{RRM} \geq V$		mA
$t_{rr}$	$T_{vj} = 25$ °C	25	$\mu$ s
$f_G$		2000	Hz
$R_{th(j-a)}$	isolated <sup>1)</sup>	8,5	K/W
	chassis <sup>2)</sup>	3,3	K/W
$R_{th(j-c)}$	total	0,7	K/W
$R_{th(c-s)}$	total	0,1	K/W
$T_{vj}$		- 40 ... + 150	°C
$T_{stg}$		- 55 ... + 150	°C
$V_{isol}$	a. c. 50 ... 60 Hz; r.m.s.; 1 s / 1 min.	3000 / 2500	V~
$M_s$	to heatsink	5 $\pm$ 15 %	Nm
$M_t$	to terminals	1,5 $\pm$ 15 %	Nm
$a$			m/s <sup>2</sup>
$w$		125	g
$F_u$		25	A
Case		G 13	

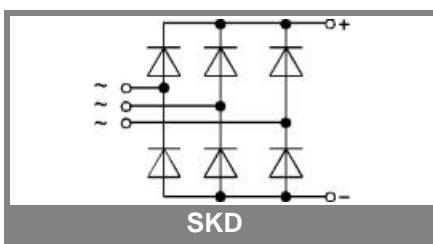

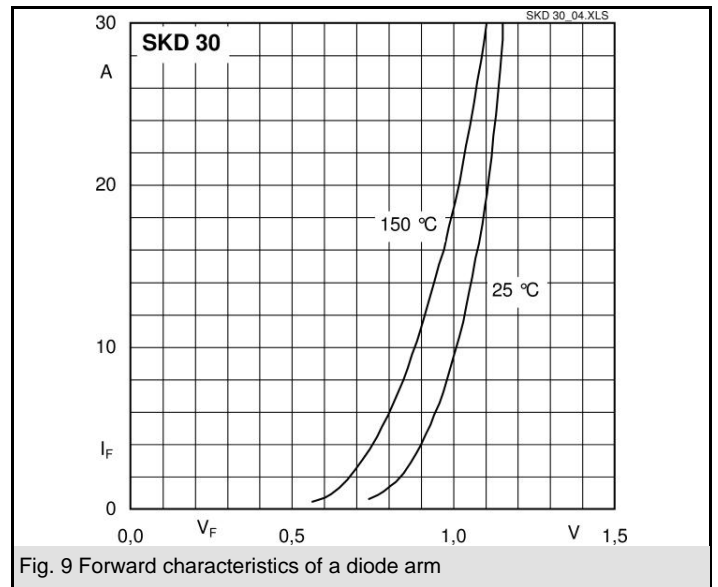
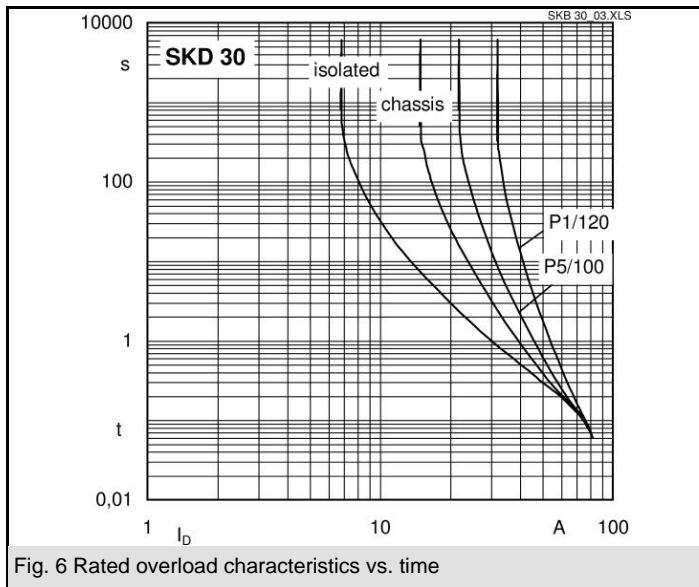
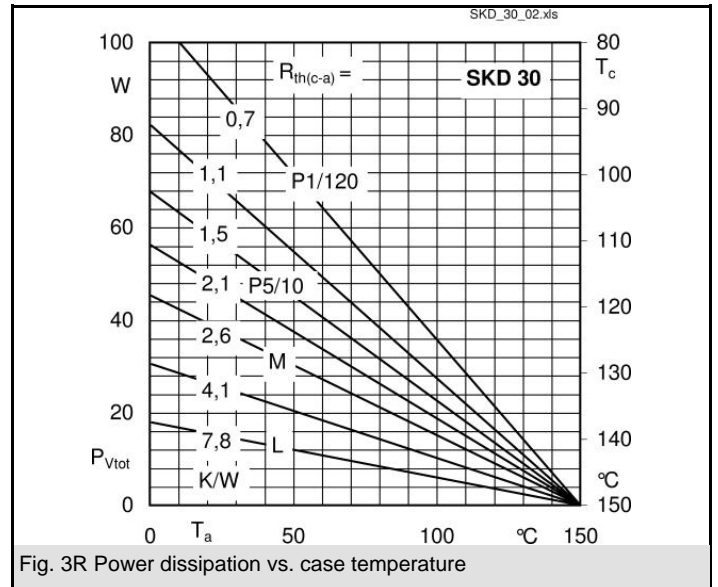
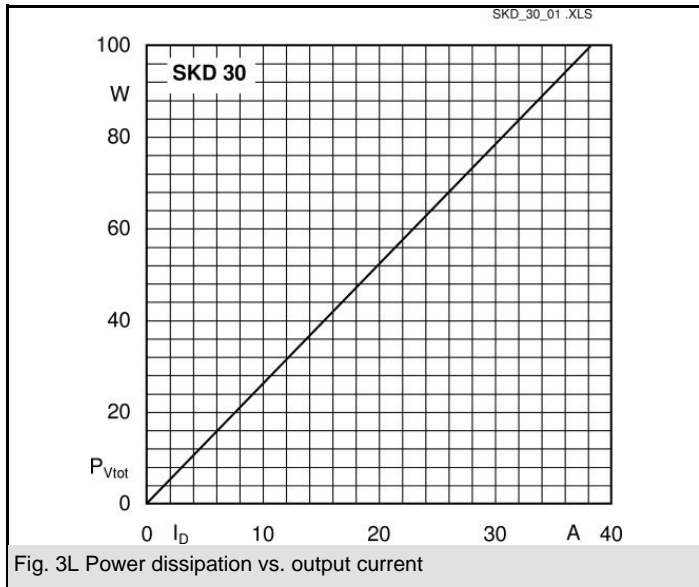

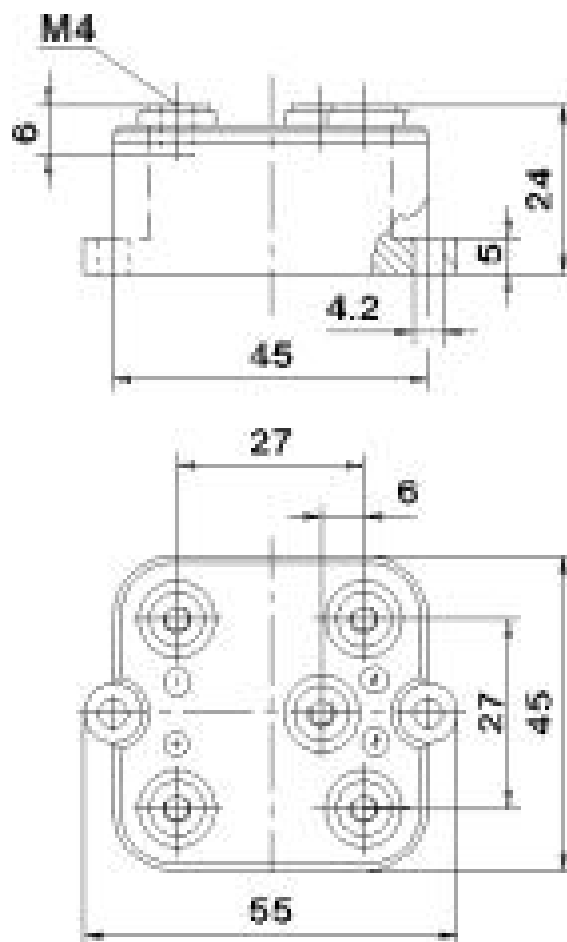

Case G 13

\* The specifications of our components may not be considered as an assurance of component characteristics. Components have to be tested for the respective application. Adjustments may be necessary. The use of SEMIKRON products in life support appliances and systems is subject to prior specification and written approval by SEMIKRON. We therefore strongly recommend prior consultation of our personal.