

1 2 3 4 5 6 7 8 9 10 11 12 13 14

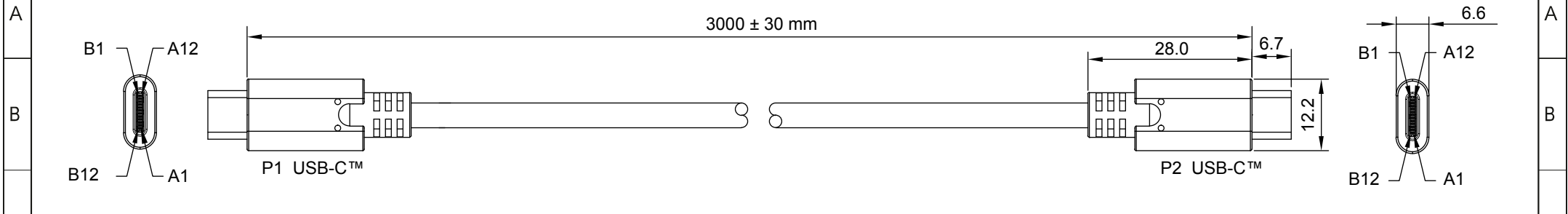

Anschlussdiagramm / Wiring diagram

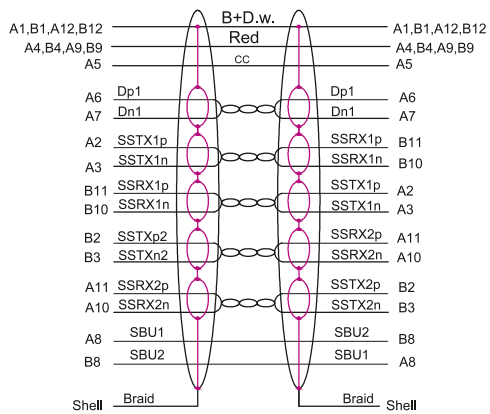

Pin-Belegung / Pin assignment

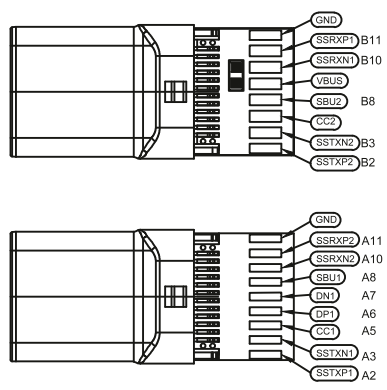

Aderquerschnitt / Wire cross section

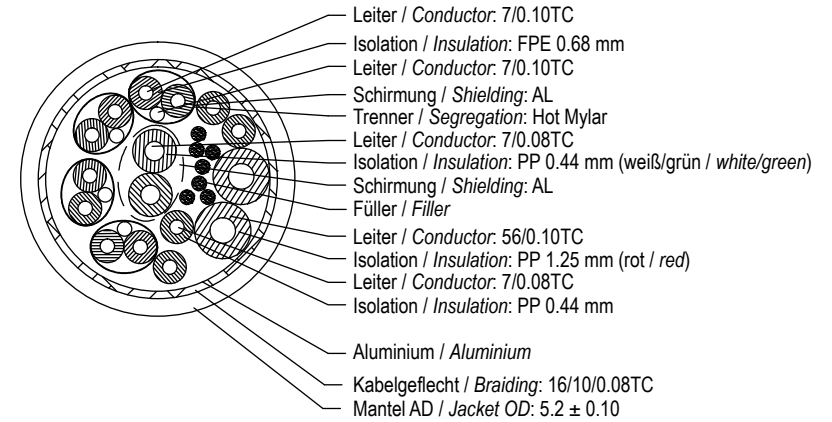

Sync & Charge Super Speed USB-C™ 3.2 Gen 1 Kabel
 - zum superschnellen Synchronisieren und Laden von USB-C™-fähigen Geräten mit einer Leistung von bis zu 60 W

Anschlüsse: 2x USB-C™-Stecker
Kontakte: vernickelt
Max. Datenübertragungsrate: 5 Gbit/s
Nennspannung: 20 V ===
Max. Stromstärke: 3 A
Kontaktwiderstand: 15 Ω max.
Isolationswiderstand: 5 MΩ min.
Material: PVC 30P, PE
Gewicht: 125 g

Sync & Charge Super Speed USB-C™ 3.2 Gen 1 Cable
 - for super-fast synchronisation and charging of USB-C™-enabled devices with a power of up to 60 W

Connectors: 2x USB-C™ male
Contacts: nickel-plated
Max. data transmission rate: 5 Gbit/s
Rated voltage: 20 V ===
Max. amperage: 3 A
Contact resistance: 15 Ω max.
Insulation resistance: 5 MΩ min.
Material: PVC 30P, PE
Weight: 125 g

Änderungen

Datum	Name	gez.:	Datum	Name
		gez.:	20.08.2021	aw
		gepr.:	20.08.2021	aw
		Norm:		
Änderungen vorbehalten / Subject to change				

Bezeichnung	Blatt
USB-C/C 0300 SCHWARZ 3.0M 	1
5G/3A PD USB 3.2 GEN1	von 1
Zeichnungs-Nr.: 66509	

1 2 3 4 5 6 7 8 9 10 11 12 13 14