

# UT210 A/B Mini Clamp Meters Operation Manual



UT210A

UT210B

## I. Overview

UT210 A/B mini digital clamp meter features high reliability, safety, precision and compact design. Its resolution ratio is 1mA. Maximum range for UT210A and B is 200A. UT210A display is average value (effective sine wave value), UT210B display is true valid value. Whole range overload protection, reliable measurement accuracy and unique appearance design makes it an outstanding new generation functional electrician/electric power measurement instrument.

## II. Open case inspection

Open the package and take out the instrument. Please check whether the following accessories are missing or damaged. If any item is missing or damaged, please contact your supplier immediately.

1. Instruction manual-----1 copy
2. 1.5V AAA battery -----2 pieces

## III. Safety precautions

This Meter complies with EN 61010-1, 61010-2-032, 61010-2-033, Pollution Degree 2, measurement category: (CATII 600V, CAT III 300V) and Double Insulation standards.

Conforms to UL STD. 61010-1, 61010-2-032, 61010-2-033 Certified to CSA STD. C22.2 NO. 61010-1, IEC STD 61010-2-032, 61010-2-033

CAT II: Applicable to test and measuring circuits connected directly to utilization points (socket outlets and similar points) of the low-voltage MAINS installation.

CAT III: Applicable to test and measuring circuits connected to the distribution part of the building's low-voltage MAINS installation, before use and follow all safety instructions.

1. Use the clamp meter by following operation instructions, otherwise safety functions of the current clamp meter may fail to protect you.
2. Abide by national safety laws and regulations. When operate in dangerous and live wire exposed environment, use personal protection equipment to prevent accidents such as electric shock and arc discharge.
3. Do not cross any position other than protective barrier of current clamp meter.
4. Before each use, check whether current clamp meter housing or output cable insulation cracks or damaged first, also check for poor connected parts. Especially pay attention to insulating layer around the clamping mouth.
5. Before removing the battery cover, please remove clamp meter from all energized circuit and disconnect lead wire.
6. Do not use clamp meter in circuit with voltage higher than 600V this or frequency higher than 400Hz.
7. Measurement category class is CAT II 600V/CAT III 300V, pollution degree is 2. Do not use it out of scope.
8. Be cautious when work in environment with exposed wire. Contact with wire may result in electric shock.
9. For voltage above 60V DC (direct current), 30V AC (AC effective value) or 42V AC (peak value), such voltage may cause electric shock.
10. Probe assemblies used for MAINS measurements CAT II 600V /CAT III 300V according to IEC 61010-031. If you want to replace the probe assemblies and they need the same level CAT II 600V /CAT III 300V or better level. Protection impairment if used in a manner not specified by the manufacturer.

## IV. Electrical symbol

	Low battery		Warning		Buzzing on-off
	Diode		Double insulation		Earthing
	Alternating current Voltage/ Direct current voltage				
	Alternating current / Direct current				
	Application around and removal from UNINSULATED HAZARDOUS LIVE conductors is permitted				
	Comply with European Union directives				
	This symbol signify the product comply with both USA and Canada requirement				

## V. General standard

1. Maximum overload protection for clamp head terminal 200A.
2. Maximum display: 2000Counts, update 2~3 times per second. Over range displays "OL".  
Work temperature: 0°C~40°C  
Relative humidity: 0°C~30°C:75%, 30°C~40°C:50%  
Storage temperature: -10°C~50°C
3. Electromagnetic compatibility:  
In 1V/m radio frequency field: overall frequency=designated precision+5% of range, radio frequency field above 1V/m has no designated index.
4. Work altitude: 0~2000m
5. Built-in battery: AAA 1.5V×2 pieces
6. Low battery: LCD displays "L".
7. Dimensions: approx. (158×60×33.5)mm, maximum clamp head size is 16mm.
8. Weight: approx. 150g (including battery)

## VI. Product panel figure

1. Clamp head.
2. Protective barrier.
3. Clamp head trigger: pull the trigger to open clamp head.
4. Function selection button: rotate this button to switch to corresponding functions indicated on the panel.
5. HOLD key: click this key to hold current reading.
6. MAXH key: click this key to maintain maximum value; click it once to maintain and click again to exit.
7. Backlight: long press for 2s to turn on or turn off backlight.
8. HOLD/backlight key: for measuring readings/long press 2s to turn on or turn off backlight.
9. REL key: click this key to make current display value reference value, then display difference value between measuring value and reference value. Click this key again to exit this function.
10. MAX/MIN key: click this key to display maximum value, click it again to display minimum value, click it one more time, it will display (MAX-MIN), it goes on and on. Long press this key for more than 2s to exit this function.
11. LCD display screen: measurement function, symbol and numerical value.
12. Indication mark for geometric center of the clamp head.

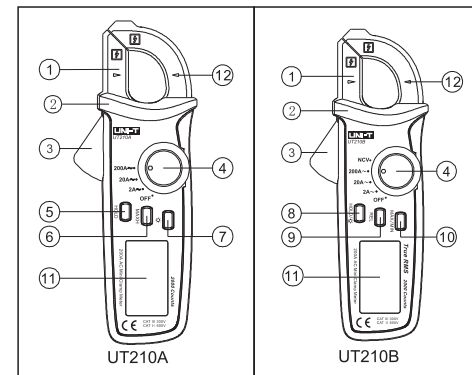

Figure 1

## VII. LCD full view figure (Figure 2)

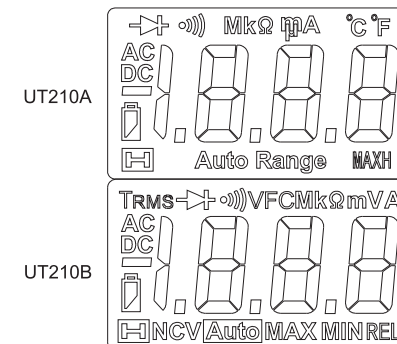

Figure 2

No.	Symbols	Instructions
1	TRMS	True valid value measurement status prompt
2	AC/DC	AC/DC voltage measurement prompt
3	-	Negative reading
4	→	Diode measurement prompt
5	·	Circuit on-off measurement prompt
6	□	Data hold prompt
7	MAXH	Maximum value hold prompt
8	MAX	Maximum value hold prompt
9	MIN	Minimum value hold prompt
10	MAXMIN	Maximum and minimum differentiation hold prompt
11	Ω kΩ MΩ	Resistance unit: Ω, kΩ, MΩ
12	mV, V	Voltage unit: mV, V
13	mA, A	Current unit: mA, A
14	(EF)NCV	Noncontact AC voltage induction prompt
15	Auto	Auto range prompt
16	ZERO/REL	Zero/relative measurement prompt
17	VFC	Variable frequency voltage/current measurement prompt
18	L	Low built-in battery prompt
19	⏻	Auto power-off prompt

## VIII. Operation instructions

### 1. Current measurement (Figure 3)

- Select range (2A~, 20A~, 200A~)
- Open clamp head, hook electric wire (single wire), place electric wire on geometric center indicated by clamp head, make sure the left and right clamp heads are totally closed. There is no gap between the left and right clamp heads.
- Read measurement data from LCD.

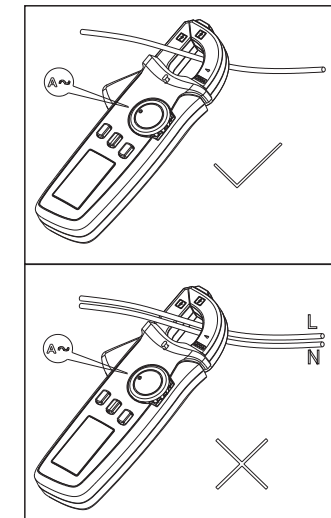

Figure 3

## 4. NCV noncontact electric field measurement (for UT210B ) Figure 4

If you want to measure whether there is AC voltage or electromagnetic field, place front end of clamp head 8~15mm close to the test piece, analog quantity of inductive AC voltage is about  $\leq$ critical voltage 100V, display "EF", > critical voltage 100V, prompt by buzzing.

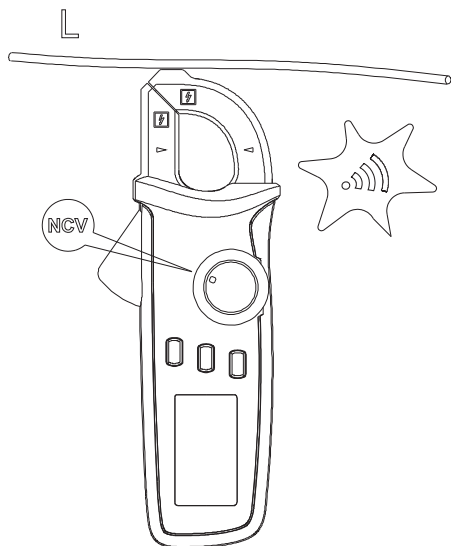



Figure 4

## 5. Other functions

- Long press HOLD key for 2s to turn on or turn off LCD backlight function.
- Automatic power-off: when measuring, if the rotary button has not pulled out in 15 minutes, the instrument will automatically power off to save energy. In automatic power-off mode, turn rotary button to OFF and restart the machine, or wake up the instrument by the following actions:
  - ① For UT210A, click any key to wake the instrument.
  - ② For UT210B, click REL key.
- Turn off automatic power-off function:
  - ① UT210A: press and hold HOLD key, press HOLD key to wake instrument under power-on start or automatic power off state, automatic power-off function will be off.
  - ② UT210B: press and hold REL key, then power-on start, you will heard 5 buzzing which means automatic power-off function is cancelled. Turn off and restart the machine, automatic power-off function will be recovered.
- The buzzer will send out 5 warnings 1 minute before automatic power off. A long buzz will be heard before power off. When automatic power-off function is canceled, you will hear 5 continuous warnings in every 15 minutes. (UT210A has no buzz warning).
- Buzzer (for UT210B ): press any key or rotate function switch, if such function key is valid, buzzer will "beep" once (lasting approx. 0.25s). When measure current outrange, buzzer will "Beep" to warn outrange, function status is as below:

200A gear: current > maximum range, buzzer beeps.

- Low-voltage detect: when battery voltage is lower than 2.5V, battery under-voltage symbol  appears, measurement accuracy may be lower once this symbol shows, replace battery timely; if it is lower than 2.2V, only battery under-voltage symbol shows after starting up, it can't work.
- When battery supply voltage lowers to 2.6V, LCD backlight will be in weak or non-start state; but measurement functions still work.

## IX. Technical index

Accuracy:  $\pm(a\%$  reading + b word count), warranty period is 1 year.  
Environment temperature: 23°C $\pm$ 5°C (73.4°F $\pm$ 9°F) relative humidity:  $\leq$ 75%

### ACA measurement

Range	Resolution	Accuracy
2.000A	1mA	$\pm (4\%+30)$
20.00A	10mA	$\pm (3\%+20)$
200.0A	100mA	$\pm (2.5\%+20)$

- ⚠ Overload protection 200A.
- Accuracy warranty coverage: 10~100% range, 2A open circuit allows <20 residue readings.
- UT210A displays average value (sine wave effective value), UT210B displays are true valid value. Frequency response: 50~60Hz.
- Non-sinusoidal wave counts add error by crest factor:
  - a) When crest factor is 1~2: Add 3%.
  - b) When crest factor is 2~2.5: Add 5%.
  - c) When crest factor is 2.5~3: Add 7%.

## X. Maintenance and repair

⚠ Warning: before remove rear cover of the instrument, make sure power supply is off.

### 1. General maintenance and repair

- \* For maintenance and repair, use wet cloth and mild cleaner to clean instrument cover, do not use grinding agent or solvent.
- \* If the instrument is abnormal, stop use it and maintain.
- \* If it is necessary to verify or maintain the instrument, maintain it by qualified professional serviceman or designated maintenance department.

### 2. Replace battery (see Figure 5)

- \* When LCD displays under-voltage  prompt, replace built-in battery immediately otherwise it will affect measurement accuracy.
- \* Battery specification: AAA 1.5V x2cells

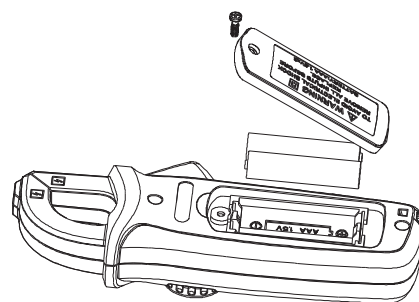

Figure 5

### Operation procedure:

1. Place power switch on "off" position.
2. Unscrew the screw fixed on the rear cover of battery by screwdriver, remove battery rear cover and take out old battery as shown in the figure.
3. Replace 2 pcs of new batteries (specification AAA1.5V)

This instruction manual is subject to change without further notice.

**UNI-T®**  
UNI-TREND TECHNOLOGY (CHINA) CO., LTD.

No6, Gong Ye Bei 1st Road,  
Songshan Lake National High-Tech Industrial  
Development Zone, Dongguan City,  
Guangdong Province, China  
Tel: (86-769) 8572 3888  
<http://www.uni-trend.com>