

KSD301 Series

1/2" DISC BIMETAL THERMOSTAT

KSD301 series snap-action bimetal thermostat is a kind of miniature hermetically sealed bimetal thermostat (1/2" disc). It is of single-pole single-throw structure and works under resistive load. KSD301 bimetal thermostat is in wide use in a great variety of compact type home appliances with automatic reset or manual reset to provide temperature control or temperature protection.

Technical Parameters:

- Rated Current: 5A/10A/16A (Resistive)
- Reset Type: Automatic/Manual
- Max OT: Resin:180°C/ Ceramic:220°C
- Resistance Between Terminals: Below 50mΩ
- Insulation Resistance: With a DC 500V megger, borne DC 500V, the tested value is over 10mΩ
- Class of Temperature Characteristics:
 - Normal Type/Normal Close: OFF temperature higher than ON temperature
 - K Type/Normal Open: ON temperature higher than OFF temperature
 - One-shot type: The thermostat switches on at room temperature and it won't be able to reset after switching off
 - Manual Reset
- Maximum Ambient Temp: ambient temperature
 - Resin: 205°C (Long period) /235°C (Less than 15 min)
 - Ceramic: 280°C (Long period) / 310°C (Less than 15 min)
- Certifications: UL/CQC/TUV

Applications:

- Coffee maker
- Toaster
- Microwave oven
- Heating
- Portable Refrigerator
- Water dispenser
- Electric pad
- Portable freezer

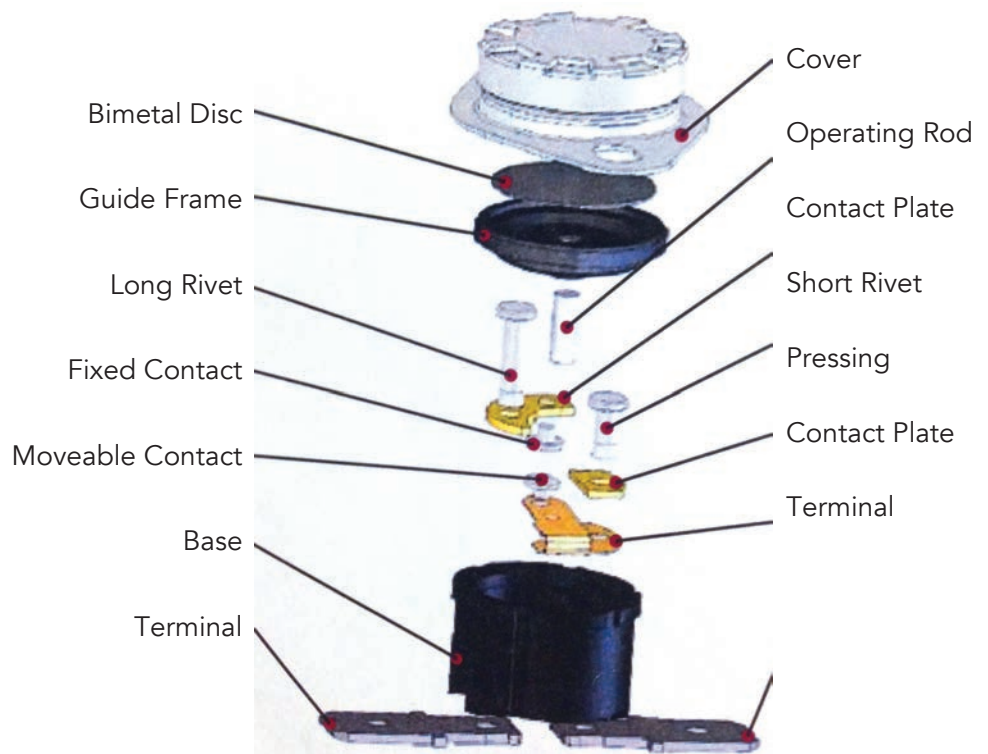

KSD301 Series

1/2" DISC BIMETAL THERMOSTAT

Code System:

KSD301 - X / X X X X - X

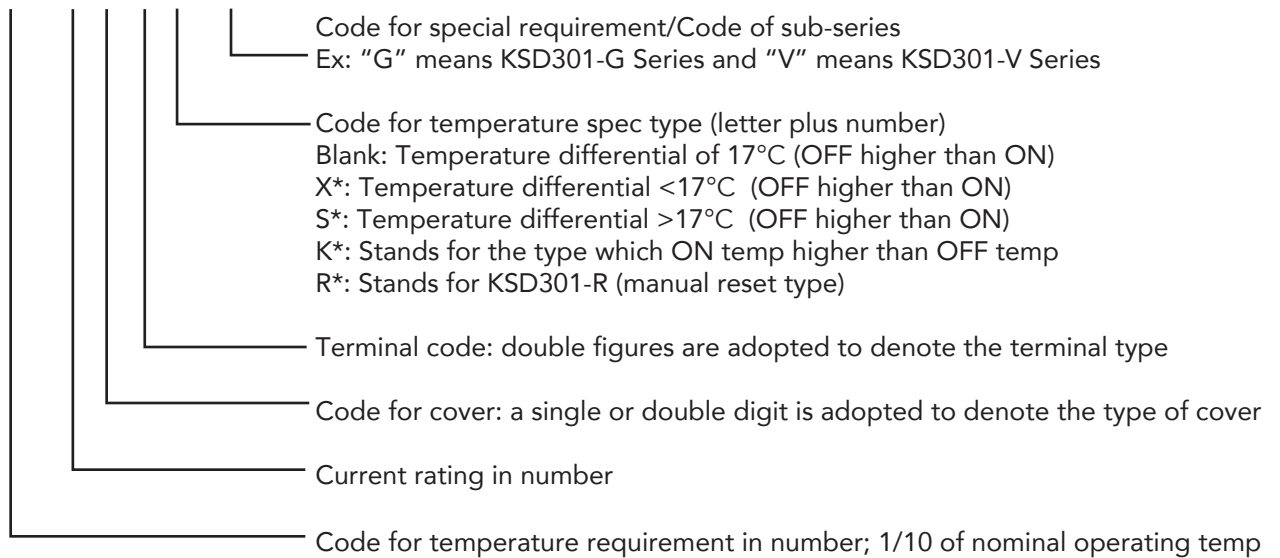

Installations:

1. Method of earth: By means of the metal cup of thermostat connected in the earthing metal part.
2. The thermostat should work in environment with humidity not higher than 90%, free of caustic, flammable gas and conducting dust.
3. When the thermostat is used to sense the temperature of solid items, its cover should be clung to the heating part of such items. Meanwhile, heat-conducting silicon grease, or other heat media of similar nature, should be applied to the cover's surface.
4. If the thermostat is used to sense the temperature of liquids or steam, it is strongly recommended to adopt a version with stainless-steel cup. Moreover, cautious measures should be taken to prevent liquids getting into/onto the thermostat's insulation parts.
5. The top of the cup must not be pressed to sink, so as to avoid adverse effect on the thermostat's temperature sensitivity or its other functions.
6. Liquids must be kept out of the thermostat's inner part! The base must avoid any force that could lead to crack; it should be kept clear and away from the pollution of electric substance to prevent insulation weakening that leads to short-circuited damages.
7. The terminals should be bent, or else, the reliability of electric connection will be influenced.

KSD301 Series

1/2" DISC BIMETAL THERMOSTAT

	Tmax. Of various OT						
	OT: $\frac{5}{\lambda}$ 50	OT:51~10 0	OT:101~14 5	OT:146~16 0	OT:161~19 0	OT:191~23 0	OT:231~28 0
KSD301 KSD301-V KSD301-R	100(L)	140(L)	185(L)	205(L)		—	—
KSD301-G KSD301-R-G	100(L)	185(L)	205(L)		245(L)	280(L)	320(L)
KSD301-G4 For coffee maker)	—	—	220(L) ($\geq 111 \square$)		—	—	—

L: Long period S: Less than 15 min

Range of OT.	Min. Diff.			
	Working current $\frac{5}{\lambda}$ 4A	Working current 4.1~8A	Working current 8.1~12A	Working current >12A
$\frac{5}{\lambda}$ 100°C	6°C	8°C	10°C	12°C
101~145°C	10°C	12°C	14°C	17°C
146~160°C	13°C	15°C	17°C	20°C
161~180°C	16°C	18°C	20°C	25°C
181~200°C	20°C	22°C	25°C	30°C
201~230°C	25°C	27°C	30°C	35°C
>230°C	30°C	32°C	35°C	40°C

Tolerance of OFF Temperature

Range of OT	Common Diff.	Limit of tolerance	
		Auto-reset	Manual reset
$\frac{5}{\lambda}$ 100°C	±3.0°C	±2.0°C	±2.5°C
101~145°C	±3.5°C	±2.5°C	±3.0°C
146~160°C	±4.0°C	±3.0°C	±3.5°C
161~180°C	±4.5°C	±3.5°C	±4.0°C
181~200°C	±5.0°C	±4.0°C	±4.5°C
201~230°C	±5.5°C	±4.5°C	±5.0°C
>230°C	±6.0°C	±5.0°C	±5.5°C

KSD301 Series

1/2" DISC BIMETAL THERMOSTAT

Range of Diff.	Range of OFF temp.	Common tolerance	Limit of the tolerance
$\frac{e}{\lambda} 7.5^{\circ}\text{C}$	$\frac{e}{\lambda} 100^{\circ}\text{C}$	$\pm 4^{\circ}\text{C}$	$\pm 3^{\circ}\text{C}$
7.6~15°C	$\frac{e}{\lambda} 100^{\circ}\text{C}$	$\pm 4.5^{\circ}\text{C}$	$\pm 3.5^{\circ}\text{C}$
	101~145°C	$\pm 5^{\circ}\text{C}$	$\pm 4^{\circ}\text{C}$
	146~160°C	$\pm 6^{\circ}\text{C}$	$\pm 5^{\circ}\text{C}$
15.1~30°C	$\frac{e}{\lambda} 100^{\circ}\text{C}$	$\pm 5^{\circ}\text{C}$	$\pm 4^{\circ}\text{C}$
	101~145°C	$\pm 6^{\circ}\text{C}$	$\pm 5^{\circ}\text{C}$
	146~160°C	$\pm 7^{\circ}\text{C}$	$\pm 6^{\circ}\text{C}$
	161~190°C	$\pm 9^{\circ}\text{C}$	$\pm 8^{\circ}\text{C}$
	191~230°C	$\pm 11^{\circ}\text{C}$	$\pm 10^{\circ}\text{C}$
30.1~45°C	$\frac{e}{\lambda} 100^{\circ}\text{C}$	$\pm 6.5^{\circ}\text{C}$	$\pm 5.5^{\circ}\text{C}$
	101~145°C	$\pm 7.5^{\circ}\text{C}$	$\pm 6.5^{\circ}\text{C}$
	146~160°C	$\pm 8.5^{\circ}\text{C}$	$\pm 7.5^{\circ}\text{C}$
	161~190°C	$\pm 10.5^{\circ}\text{C}$	$\pm 9.5^{\circ}\text{C}$
	191~230°C	$\pm 12.5^{\circ}\text{C}$	$\pm 11.5^{\circ}\text{C}$
45.1~60°C	$\frac{e}{\lambda} 100^{\circ}\text{C}$	$\pm 8^{\circ}\text{C}$	$\pm 7^{\circ}\text{C}$
	101~145°C	$\pm 9^{\circ}\text{C}$	$\pm 8^{\circ}\text{C}$
	146~160°C	$\pm 10^{\circ}\text{C}$	$\pm 9^{\circ}\text{C}$
	161~190°C	$\pm 12^{\circ}\text{C}$	$\pm 11^{\circ}\text{C}$
	191~230°C	$\pm 14^{\circ}\text{C}$	$\pm 13^{\circ}\text{C}$
60.1~75°C	$\frac{e}{\lambda} 100^{\circ}\text{C}$	$\pm 9.5^{\circ}\text{C}$	$\pm 8.5^{\circ}\text{C}$
	101~145°C	$\pm 10.5^{\circ}\text{C}$	$\pm 9.5^{\circ}\text{C}$
	146~160°C	$\pm 11.5^{\circ}\text{C}$	$\pm 10.5^{\circ}\text{C}$
	161~190°C	$\pm 12^{\circ}\text{C}$	$\pm 11^{\circ}\text{C}$
	191~230°C	$\pm 14^{\circ}\text{C}$	$\pm 13^{\circ}\text{C}$
75.1~90°C	$\frac{e}{\lambda} 100^{\circ}\text{C}$	$\pm 11^{\circ}\text{C}$	$\pm 10^{\circ}\text{C}$
	101~145°C	$\pm 12^{\circ}\text{C}$	$\pm 11^{\circ}\text{C}$
	146~160°C	$\pm 13^{\circ}\text{C}$	$\pm 12^{\circ}\text{C}$
	161~190°C	$\pm 15^{\circ}\text{C}$	$\pm 14^{\circ}\text{C}$
	191~230°C	$\pm 17^{\circ}\text{C}$	$\pm 16^{\circ}\text{C}$
90.1~105°C	$\frac{e}{\lambda} 100^{\circ}\text{C}$	$\pm 12.5^{\circ}\text{C}$	$\pm 11.5^{\circ}\text{C}$
	101~145°C	$\pm 13.5^{\circ}\text{C}$	$\pm 12.5^{\circ}\text{C}$

KSD301 Series

1/2" DISC BIMETAL THERMOSTAT

Type and Dimension of Cover and Terminal:

The materials of cover include aluminum, brass, and stainless steel. If the thermostat is used to sense to temperature of liquids or steam, it should use the stainless version.

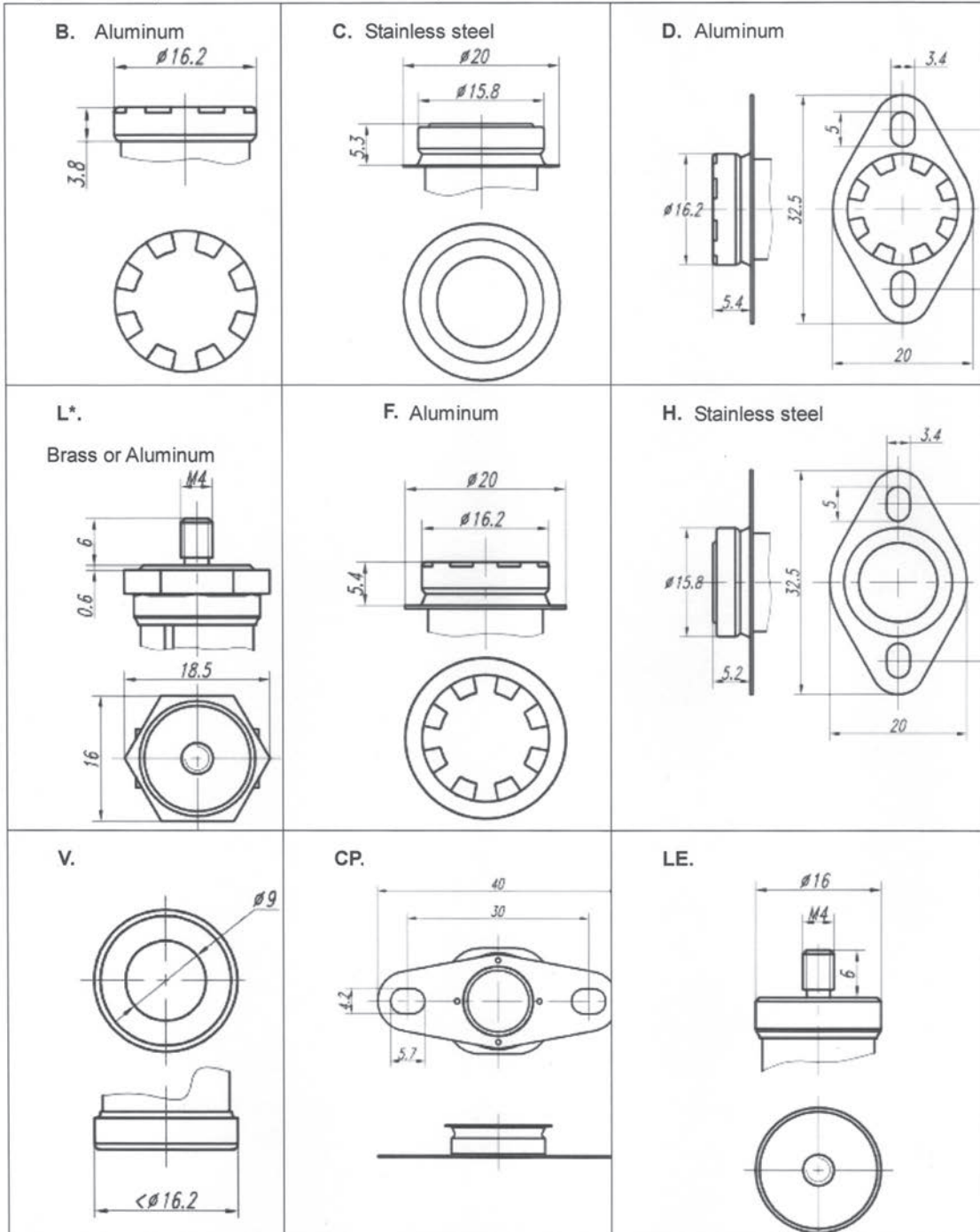

KSD301 Series

1/2" DISC BIMETAL THERMOSTAT

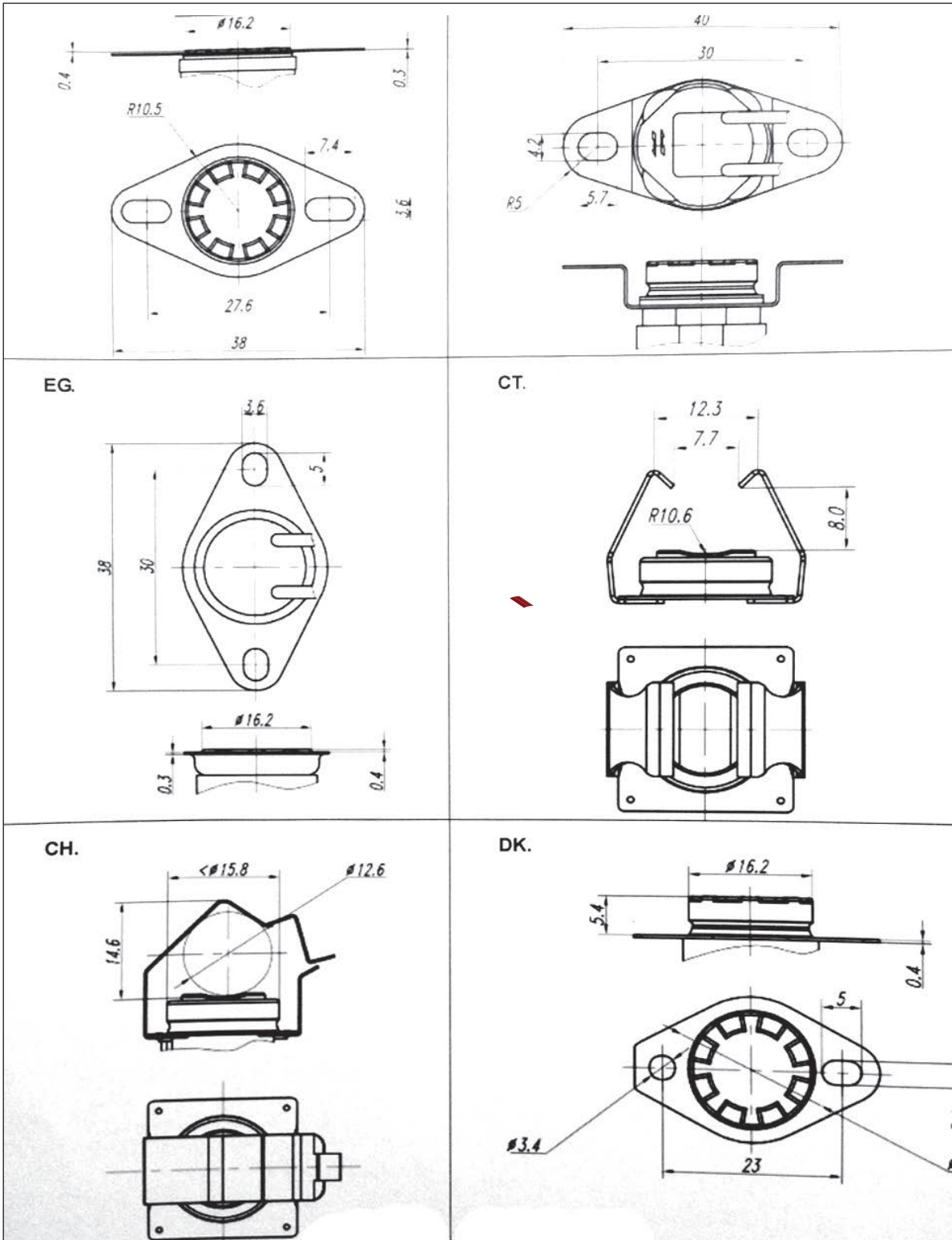

KSD301 Series

1/2" DISC BIMETAL THERMOSTAT

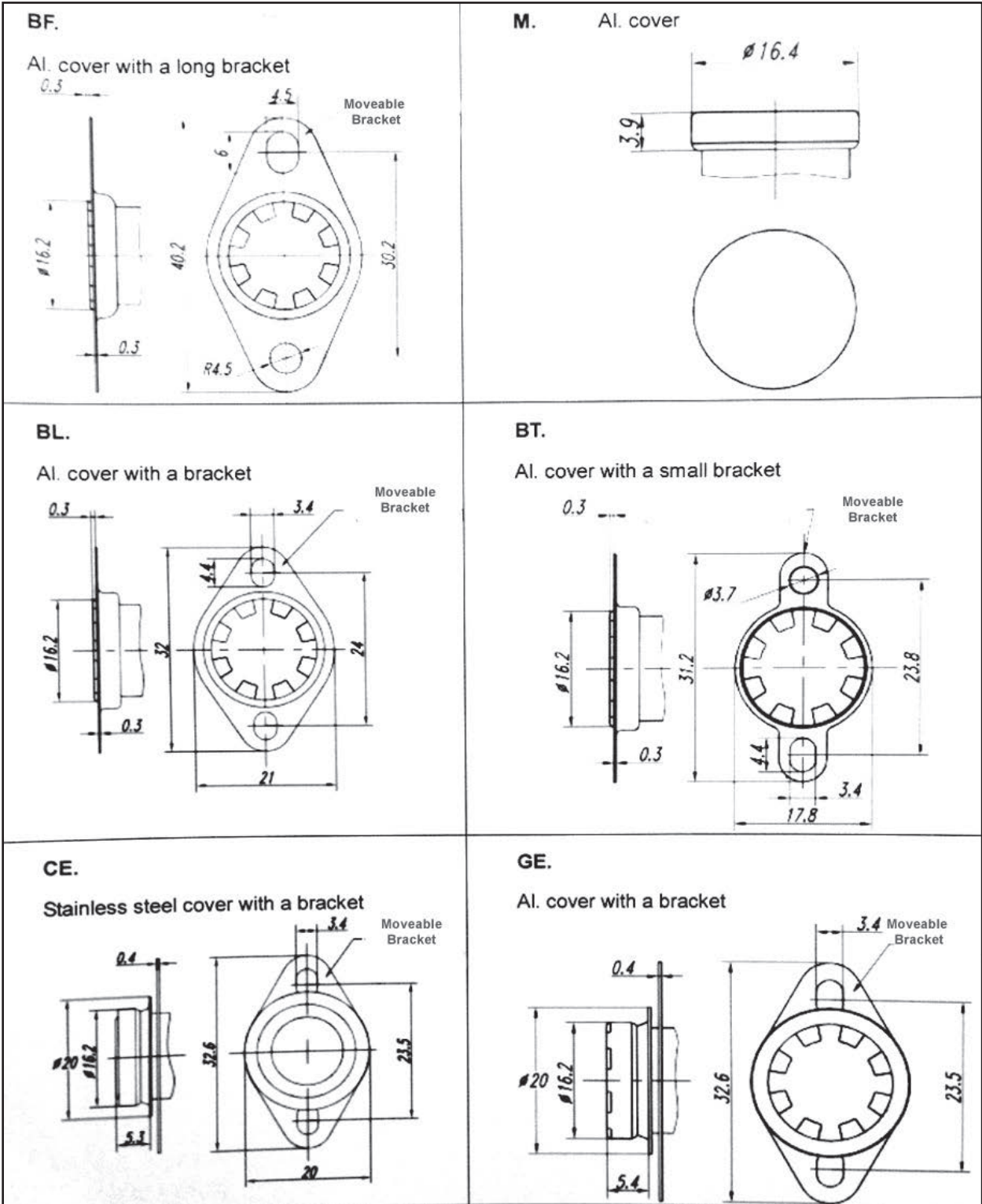

KSD301 Series

1/2" DISC BIMETAL THERMOSTAT

