

REV.	DESCRIPTION	DRAWN	CHECKED	APPROVED
A	NEW RELEASE	YCH 09/03/10'	~	

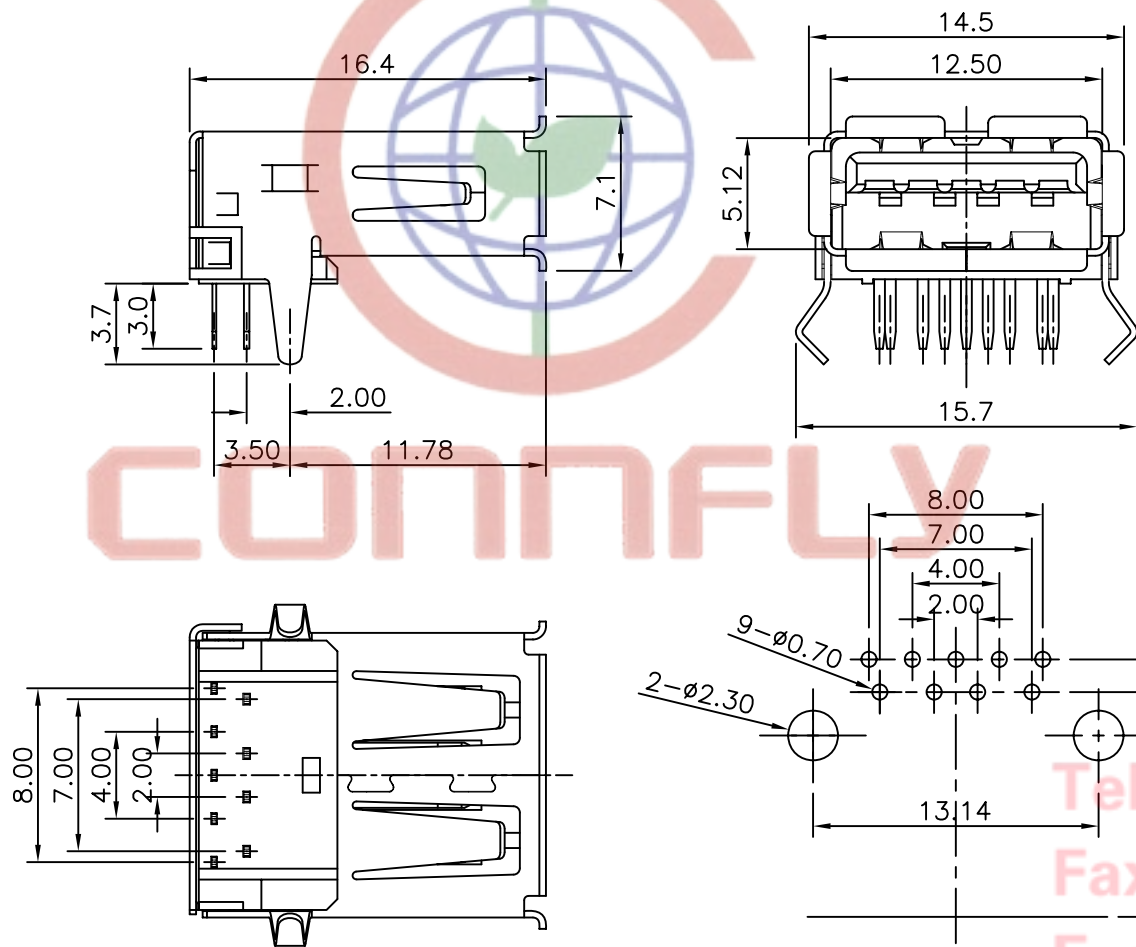

- NOTES:
- SPECIFICATIONS:
 - CONTACT RESISTANCE: 30mΩ(max.) INITIAL FOR VBUS AND GND CONTACTS. 50mΩ(max.) INITIAL FOR ALL OTHER CONTACTS.
 - INSULATOR RESISTANCE: 100MΩ min. AT 100V DC.
 - CURRENT RATING: 1.8A FOR VBUS PIN AND ITS CORRESPONDING GND PIN. 0.25A (MIN.) FOR ALL OTHER CONTACTS
 - VOLTAGE RATING: 30V AC/DC.
 - DIELECTRIC STRENGTH: AC 100V FOR 1 Minute.
 - OPERATING TEMPERATURE: -55°C ~ +85°C.
 - MATERIALS:
 - HOUSING: THERMOPLASTIC (UL 94-0).
 - CONTACT: COPPER ALLOY
 - SHELL: COPPER ALLOY.
 - PRODUCT NUMBER CODE:

DS1095-05-X X X X

 - CONTACT PLATING
 - 0: Selective gold flash
 - 03: Selective gold 3u"
 - 30: Selective gold 30u"
 - MOUNTING TYPE
 - R: R/A
 - SHELL PLATING:
 - N: Nickel
 - 6: Tin
 - COLOR OF HOUSING:
 - L: Blue
 - W: White
 - B: Black

RECOMMEND PCB LAYOUT
(TOLERANCE=±0.05)

Tel: 86-574-6350787
 Fax: 86-574-63510817
 E-mail: sale@zhenqin.com.cn
 Http://www.connfly.com

GENERAL TOLERANCE		ANGLE TOLERANCE		PROJECTION		TITLE	USB 3.0 A TYPE FEMALE R/A TYPE		
X.	±0.60	X.	±5°	UNITS	mm				
.X	±0.38	.X	±3'	SHEET SIZE	A4	SERIES	DS1095-05 SERIES		
.XX	±0.25	.XX	±2'						
DRAWING TYPE		CUSTOMER				晨翔电子有限公司 CONNFLY CONNFLY ELECTRONIC CO. LTD			
SCALE		1:1	SHEET						1 OF 1
DRAWING NO.		C-DS1095-05-XXRX							