

LZ15-GW2-B

Features

1. Rating: 15A 125/250VAC
2. Various actuator are available
3. High precision, fast action
4. High mechanical strength
5. Long life, stable and reliable
6. CCC, CE, UL approvals

Application Area

Widely applied in machinery, production line, elevator equipment etc.

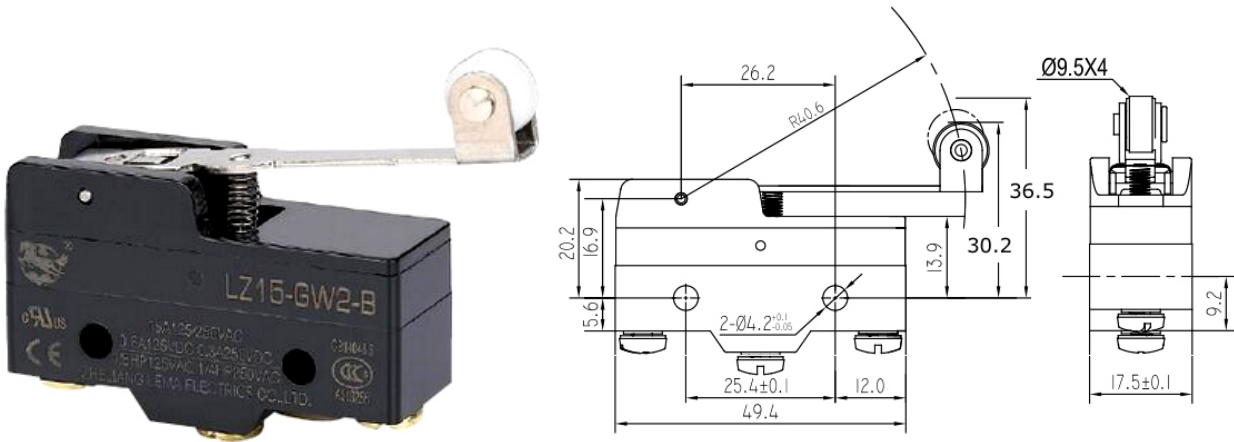

| | | |
|-------------------------------|------------------------------------------------------------|---------------------------------|
| Rating | | 15A 125/250VAC |
| Initial contact resistance | | 25mΩ max. |
| Initial insulation resistance | | 100MΩ min. (at 500VDC) |
| Dielectric strength | Between non-consecutive terminals | 1000Vrms, 50/60Hz for 1 min |
| | Between non-current carrying metal parts and each terminal | 2000Vrms, 50/60Hz for 1 min |
| | Between ground and each terminal | 2000Vrms, 50/60Hz for 1 min |
| Max.shock resistance | Destruction | 1000m/s ² max. |
| | Malfunction | 300m/s ² max. |
| Vibration resistance | | 10-55Hz, 1.5mm double amplitude |
| Operating life | Mechanical life | 1,000,000 operations min. |
| | Electrical life | 100,000 operations min. |
| Ambient temperature | | -25°C to +85°C |
| Ambient humidity | | 85% RH max. |
| Operating frequency | Mechanical | 240 operation/min |
| | Electrical | 20 operation/min |
| Operating speed | | 0.01mm-1m/s |
| Protection degree | | IP40 |