

LZ15-GW49-B

Features

1. Rating: 15A 125/250VAC
2. Various actuator are available
3. High precision, fast action
4. High mechanical strength
5. Long life, stable and reliable
6. CCC, CE, UL approvals

Application Area

Widely applied in machinery, production line, elevator equipment etc.

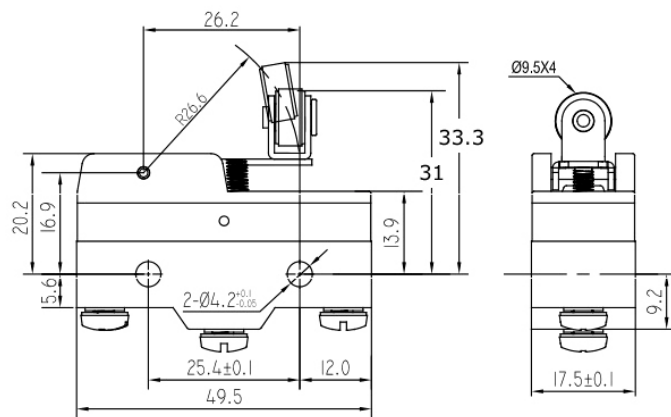

Rating		15A 125/250VAC
Initial contact resistance		25mΩ max.
Initial insulation resistance		100MΩ min. (at 500VDC)
Dielectric strength	Between non-consecutive terminals	1000Vrms, 50/60Hz for 1 min
	Between non-current carrying metal parts and each terminal	2000Vrms, 50/60Hz for 1 min
	Between ground and each terminal	2000Vrms, 50/60Hz for 1 min
Max.shock resistance	Destruction	1000m/s ² max.
	Malfunction	300m/s ² max.
Vibration resistance		10-55Hz, 1.5mm double amplitude
Operating life	Mechanical life	1,000,000 operations min.
	Electrical life	100,000 operations min.
Ambient temperature		-25°C to +85°C
Ambient humidity		85% RH max.
Operating frequency	Mechanical	240 operation/min
	Electrical	20 operation/min
Operating speed		0.01mm-1m/s
Protection degree		IP40